

P/N:110401112266X

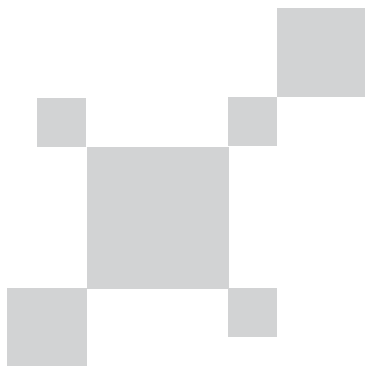

UNI-T[®]

UNI-TREND TECHNOLOGY (CHINA) CO., LTD.

No. 6, Gong Ye Bei 1st Road,
Songshan Lake National High-Tech Industrial
Development Zone, Dongguan City,
Guangdong Province, China
Tel: (86-769) 8572 3888
<http://www.uni-trend.com>

UNI-T[®]



DOUBLE CLAMP MULTIFUNCTIONAL EARTH TESTER

UT575B
Operating Manual



Contents

I.	Safety Information	1
II.	Introduction	2
III.	Technical Specifications	3
	1) Benchmark and Working Conditions	3
	2) General Specifications	3
	3) Basic Errors and Performance Specifications under Benchmark Conditions	6
IV.	III. Tester Structures	7
V.	IV. Functional Knob	9
VI.	V. LCD Display	10
VII.	VI.Measurement Rationales	11
VIII.	VII.Operating Instructions	15
	1) Power On/Off	15
	2) Check the Battery Voltage	15
	3) Simple 2-Wire Method	15
	4) 3-Wire Method	16
	5) 4-Wire Precision Method	17
	6) 4-Wire Selection Method	19
	7) Single-Clamp 3-Wire Selection Method	21
	8) Double-Clamp Method	21
	9) Soil Resistivity Testing	22
	10) DC Resistance Testing	24
	11) AC Current Testing	25
	12) Grounding Voltage Testing	25
	13) Backlight Control	26
	14) Alarm Setting	27
	15) Data Hold/Storage	27
	16) Data Viewing/Deletion	27
	17) Data Uploading	28
IX.	VIII.Battery Charging	28
X.	IX.Packing List	29

Safety Information

Thank you for buying this product, for better use of it, please be sure of the followings:

Read the user manual carefully.

Follow all operating precautions in the user manual.

- ◆ The tester is designed, manufactured and inspected according to IEC61010 safety standard.
- ◆ Pay special attention to safety use in any case.
- ◆ The USB port is not isolated with internal circuit, it is forbidden to connect with computer during voltage testing. Otherwise it will cause tester damage or electric shock. Before connecting USB cable with the computer to read data, please disconnect the voltage test lead with the tester.
- ◆ The on-line monitoring mentioned in the user manual is applicable to voltage monitoring.
- ◆ Please pay attention to the text and symbol on the label at the tester.
- ◆ Pay attention to the current direction of the current clamp when performing grounding resistance test.
- ◆ Please make sure that the tester and its accessories are intact. If the insulations of the tester and test lead are damaged, or the lead is bare or broken, please do not use!
- ◆ It is forbidden to make contact with the bare conductor and the circuit under measurement.
- ◆ Please set the functional knob at corresponding position before measurement.
- ◆ Make sure that the plug of the test lead is well connected with the port of the tester.
- ◆ Do not apply grounding voltage over 100V between the test end and the port, otherwise the tester may be damaged.
- ◆ Do not perform measurement in inflammable places, the spark may cause explosion.
- ◆ If exposed metal occurs due to crack of the casing or test lead during use, please stop using immediately.
- ◆ Do not place and keep the tester in places with high temperature, high humidity, dews and direct sunlight for an extended period of time.
- ◆ Please make sure the tester is dry before storing it.
- ◆ Remove the test lead from the tester and set the functional knob at "OFF" position before replacing the battery.
- ◆ Please charge the tester in time if the low battery symbol "" is displayed.
- ◆ If the tester is not used for an extended period of time, please charge the tester once every one or two months to avoid battery damage.
- ◆ Use, disassembly, calibration and repair must be performed by authorized eligible

personnel.

- ◆ If danger occurs due to the meter, please stop using the meter immediately, then seal the meter and send it to authorized qualified agency for maintenance
- ◆ The symbols “ at the tester and user manual represent danger warning, indicating user must perform safe operation according to the warnings.

I. Introduction

UT575B Double-Clamp Multifunctional Earth Tester is a high-end meter designed and manufactured for measuring grounding resistance, DC resistance, soil resistivity, grounding current and grounding voltage. User can perform measurement with multiple measurement methods such as 2/3/4-wire, selection, double-clamp, etc. Digital processing, FFT and AFF technologies are employed. The tester is capable of resisting interference and adapting the environment and the results of repeated tests are consistent, which ensure high precision, stability and reliability. The jaw opening of the current clamp is large, allowing the tester to be used in measurement of grounding resistance of down lead with large size, measurement of grounding resistance of various complicated grounding structures (i.e. single-point, grid-shaped groundings, etc.), measurement of parallel grounding system without any parallel grounding electrode disconnected, providing perfect solutions for the grounding performance test.

The tester is supplied along with current clamp (double clamps), test leads, auxiliary ground rod, communication software, communication cable, etc. The large LCD screen with backlight and bar graph indication makes the display are clear. The tester has storage and clock functions, it can automatically stores 2000 groups of testing data with data and time. With USB port designed for the tester, the stored data can be uploaded to the monitoring software in computer, which enable data access, data viewing, data storage, data report generation, data printing, and other functions. UT575B is extensively applied in a variety of industries including electric power, telecommunication, meteorology, oil field, architecture, lightning protection, industrial electrical equipment, etc.

Features:

1. Indicator light with unique design for the jack to enable correct position indication and avoid misoperation.
2. 12-position functional knob to display different testing methods clearly.
3. Water-proof (IP65), anti-impact and drop-proof casing to make the tester robust, safe,

durable, and particularly suitable for outdoor use.

4. Equipped with rechargeable lithium battery pack with large capacity. Data to be uploaded via USB port.

II. Technical Specifications



1. Benchmark and Working Conditions

Influencing Quantity	Benchmark Condition	Working Condition	Remark
Environment temperature	23°C±1°C	-10°C~40°C	----
Environment humidity	40%~60%	<80%	----
Operating voltage	7.8V±0.1V	DC 7.8V±0.6V	----
Auxiliary grounding resistance	<100	<5k	
Interference voltage	Should be avoided	<20V	
Interference current	Should be avoided	<2A	
Electrode spacing when measuring R	a>5d	a>5d	
Electrode spacing when measuring	a>20h	a>20h	

2. General Specifications

Functions	Grounding resistance, DC resistance, soil resistivity, grounding voltage, grounding current measurements.	
Light source	DC 7.4V 2600mAh rechargeable lithium battery. The voltage of fully-charged battery is about 8.4V.	
Backlight	Controllable backlight enables the tester to be used in dim environments.	
Measurement methods	DC resistance	2-pin method
		4-pin method
	Grounding resistance	2-pin method
		3-pin method

		4-pin method
		Single-clamp 3-pin method (Selection method)
		Single-clamp 4-pin method (Selection method)
		Double-clamp method
		Soil resistivity (Wenner method)
	Grounding current	By current clamp
	Grounding voltage	By rectifying the average value
Testing frequency	128Hz/111Hz/105Hz/94Hz (Automatic Frequency Control)	
Short-circuit current	AC 250mA max	
Open-circuit voltage	AC 40V max	
Electrode spacing range	1m~100m	
Display mode	4-digit ultra large LCD display with backlight.	
Measurement indication	The LED flashes during measurement, and countdown display shows on the LCD.	
LCD size	128mm×75mm	
LCD display area	124mm×67mm	
Tester dimension	280mm×260mm×160mm (Height*Width*Thickness)	
Clamp dimension	223mm×120mm×39mm (Height*Width*Thickness)	
Test lead	There are four leads including 20m red lead, 20m black lead, 10m yellow lead and 10m green lead.	
Simple test lead	There are two leads including 1.6m red lead and 1.6 black lead.	
Auxiliary ground rod	Quantity: 4pcs; Diameter: 10mm×250mm; Weight: 935g	
Current clamp	Blue-black plug: 1pcs Red-black plug: 1pcs	
Clamp diameter	70mm	
Clamp lead length	2m	
Measurement time	AC current: About 2 times per second Voltage to earth: About 2 times per second Earth resistance: About 7 seconds each time.	

Measurement cycle	>5000 cycles (Perform short-circuit test once, retest after stopping for 30 seconds)
Circuit voltage	<AC 600V
Communication mode	Storage data can be uploaded to computer via USB interface and software.
USB cable	Quantity: 1pcs Length: 1.5m
Data hold	The symbol "HOLD" shows up when holding data.
Data storage	The symbol "MEM" shows up when storing data. The symbol "FULL" displays to indicate full storage (2000 groups of data).
Data viewing	The symbol "READ" is displayed when viewing data.
Overrange indication	The symbol "OL" is displayed.
Low current indication	If the current signal received by CT2 is lower than 0.5mA when performing measurement with "Selection method" or "Double-clamp method", the symbol  will be displayed, please check the clamping direction of CT2 current clamp.
Interference testing	Interference signal is identified automatically. The symbol "NOISE" will be displayed to indicate interference voltage over 5V.
Auxiliary grounding test	The tester has function of auxiliary grounding resistance test. 0.00k ~30.00k (100R+rC<50k , 100R+rP<50k)
Alarming function	If the measured value exceeds the alarming threshold, the buzzer will make "Beep—Beep--Beep" sound as an alarm indication.
Battery voltage	When the battery voltage is about DC 7.2V±0.1V, the symbol  will appear to indicate that the tester needs to be charged.
Auto power off	The tester will power off automatically after it starts up for about 15 minutes.
Operating current	Backlight: 25mA Max (Individual power consumption of backlight)
	Standby: 25mA Max (Backlight is off after the tester is turned on)
	Measurement: 150mA Max (Backlight is off)
Weight	Tester: 3490g approximately (Battery included)
	Current clamp: 1100g approximately (2PCS)
	Total weight: 6800g approximately (Accessories included)

Operating temperature and humidity	-10°C~40°C; <80%rh
Storage temperature and humidity	-20°C~60°C; <70%rh
Protection degree	IP65 (With the cover closed)
Overload protection	Grounding resistance measurement: 280V/3s between C(H)-E, P(S)-ES and each terminal.
Insulation resistance	>20M (500V between electric circuit and casing)
Withstand voltage	AC 3700V/rms (between electric circuit and casing)
Electromagnetic characteristic	IEC61326 (EMC)
Category rating	IEC61010-1 (CAT III 300V, CAT IV 150V, Pollution degree 2) IEC61010-031 IEC61557-1 (Grounding resistance) IEC61557-5 (Soil resistivity)

3. Basic Errors and Performance Specifications under Benchmark Conditions

Measurement function	Measurement range	Accuracy	Resolution
Grounding resistance (R~) and DC resistance (R ₋₋₋) measurement with 2/3/4-wire method	0.00 ~29.99	±2%rdg±5dgt	0.01
	30.0 ~299.9	±2%rdg±3dgt	0.1
	300 ~2999	±2%rdg±3dgt	1
	3.00k ~300.00k	±4%rdg±3dgt	10
Grounding resistance	0.00 ~29.99	±2%rdg±5dgt	0.01
	30.0 ~299.9	±2%rdg±3dgt	0.1

(R~) measurement with selection method	300 ~3000	$\pm 2\% \text{rdg} \pm 3 \text{dgt}$	1
Grounding resistance (R~) measurement with double-clamp method	0.01 ~0.99	$\pm 10\% \text{rdg} \pm 5 \text{dgt}$	0.01
	1.0 ~29.9		0.1
	30 ~100		1
Soil resistivity ()	0.00 m~99.99 m	The accuracy depends upon the measurement accuracy of R. (=2 aR a:1 m~100m; =3.14)	0.01 m
	100.0 m~999.9 m		0.1 m
	1000 m~9999 m		1 m
	10.00k m~99.99k m		10 m
	100.0k m~999.9k m		100 m
	1000k m~9000k m		1k m
Grounding interference voltage (V~) 50Hz/60Hz	AC 0.0~100.0V	$\pm 2\% \text{rdg} \pm 3 \text{dgt}$	0.1V
Grounding interference current (A~) 50Hz/60Hz	AC 0.00mA~600.0A	$\pm 2\% \text{rdg} \pm 3 \text{dgt}$	0.01mA

Note:

1. The additional error is $\pm 5\% \text{rdg} \pm 5 \text{dgt}$ for rC max or rP max. (rC max: 4k +100R<50k , rP max: 4k +100R<50k)
2. The additional error is $\pm 5\% \text{rdg} \pm 5 \text{dgt}$ for interference voltage of 5V.

III. Tester Structures

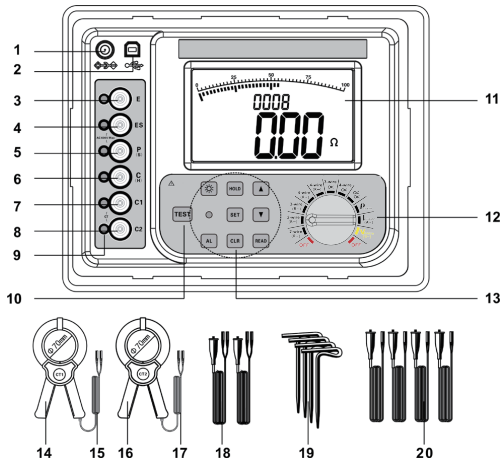

1. Charging port
2. USB port
3. E port (Grounding electrode)
4. ES port (Auxiliary grounding electrode)
5. P(S) port (Voltage electrode)
6. C(H) port (Current electrode)
7. C₁ port (Port of same-polarity end of CT2)
8. C₂ port (Port of common end of CT2)

9. Indicator light
10. TEST button
11. LCD screen
12. Functional knob
13. Functional buttons

14. Excitation current clamp (CT1)
15. Connectors of excitation current clamp, red for same-polarity end, black for common end

16. Received current clamp (CT2)

17. Connectors of received current clamp, blue for same-polarity end, black for common end

18. Simple test leads

19. Auxiliary ground rods

20. Test leads

IV. Functional Knob

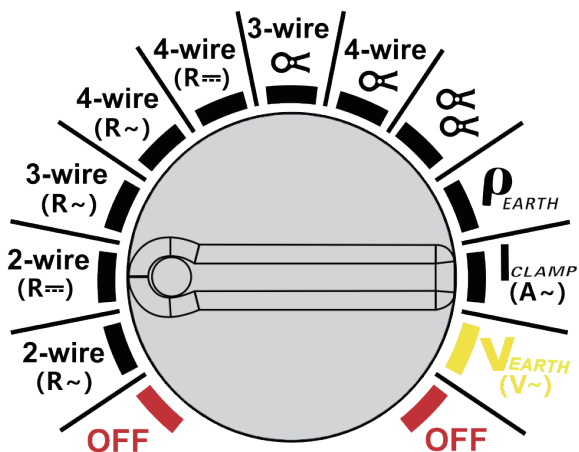

Position	Function	Position	Function
OFF	Power off	3-Wire	Grounding resistance testing with three-pin selection method
2-Wire (R~)	Grounding resistance testing with two-pin method	4-Wire	Grounding resistance testing with four-pin selection method
2-Wire	DC resistance testing with two-pin method	Grounding	Grounding resistance testing with double-clamp method

(R-)			
3-Wire (R~)	Grounding resistance testing with three-pin method	Soil resistivity(P)	Soil resistivity testing with Wenner method
4-Wire (R~)	Grounding resistance testing with four-pin method	Current(A~)	Interference current of grounding
4-Wire(R~)	DC resistance testing with four-pin method	Voltage(V~)	Interference voltage of grounding

V. LCD Display

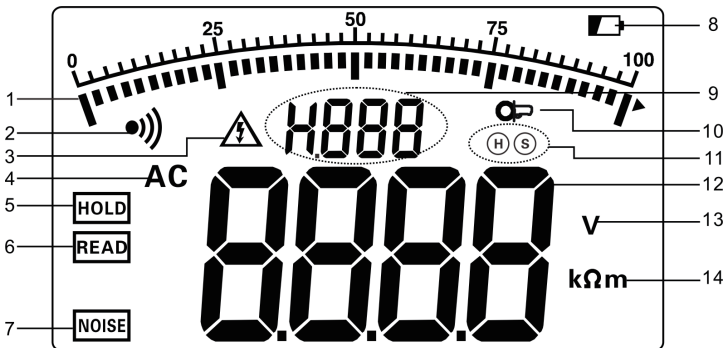

1. Progress bar (Testing progress is displayed dynamically)
2. Alarm symbol (This symbol is displayed when alarm function is enabled, and it flashes when alarm threshold is exceeded)
3. Overvoltage indication (This symbol appears when the tested voltage exceeds 30V.)

4. Alternating current indication
5. Data hold indication (This symbol is displayed when **HOLD** button is pressed)
6. Data viewing indication (This symbol is displayed when **READ** button is pressed for 3 seconds)
7. Interference signal indication (The symbol is displayed when interference voltage exceed 5V)
8. Low battery indication (The symbol shows up when the battery voltage is lower than 7.5V)
9. Number of groups of stored data
10. The symbol appears when the current signal received by CT2 current clamp is lower than 0.5mA, which may be caused by reverse clamping direction of CT2 current clamp.
11. Electrode interference indication (The symbol is displayed when the electrode is interfered)
12. Testing data
13. Voltage unit
14. Resistance unit, soil resistivity unit, current unit, length unit

VI. Measurement Rationales

1. For grounding resistance measurement with 3/4-wire method, the rated-current pole-changing method is adopted (suitable for accurate measurement of single-point grounding system), that is, the AC rated current "I" flows between the measured grounding electrode "E" and the current electrode C(H). The potential difference "V" between the grounding electrode "E" and voltage electrode "P(S)" is measured, and the grounding resistance "R" is calculated according to the formula " $R=V/I$ ". To ensure testing accuracy, 4-wire method is adopted and auxiliary grounding electrode "ES" is added, both "ES" and "E" are clamped at the same point of the grounding conductor in actual testing.

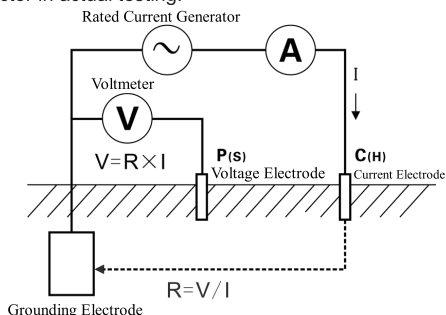

2. For grounding resistance measurement with selection method, the current pole-changing method is adopted (suitable for measuring the grounding resistance of one of grounding grids of parallel grounding system when not tripped), that is, the alternating current “I” is applied between the current electrode “C(H)” and grounding electrodes (Re1, Re2, Re3), the current “I3” flowing through “Re3” is measured with CT2, and the potential difference “V” between the grounding electrode “Re3” and voltage electrode “P(S)” is measured, then the grounding resistance “Re3” is calculated according to the formula “ $Re3=V/I3$ ”. To ensure testing accuracy, 4-wire method is adopted and auxiliary grounding electrode “ES” is added, both “ES” and “E” are clamped at the same point of the grounding electrode in actual testing.

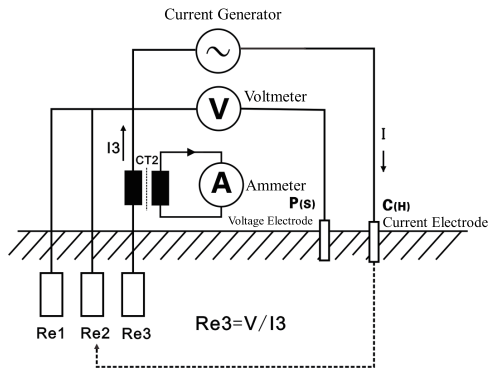

3. For grounding resistance measurement with double-clamp method (suitable for performing measurement without auxiliary ground stud on the condition that multiple individual points are connected with grounding system in parallel), an AC electromotive force “V” is produced through the excitation clamp CT1, the current “I” is produced in the loop under the action of AC electromotive force “V”, and the feedback current “I” is detected with CT2, then the resistance is calculated according to the formula “ $R=V/I$ ”. As shown in the figure below, R equals $Re+R1//R2//R3//...Rn-1//Rn$, if $R1//R2//R3//...Rn-1//Rn$ (the parallel resistance of multiple grounding points) is far less than Re, then R approximately equals Re.

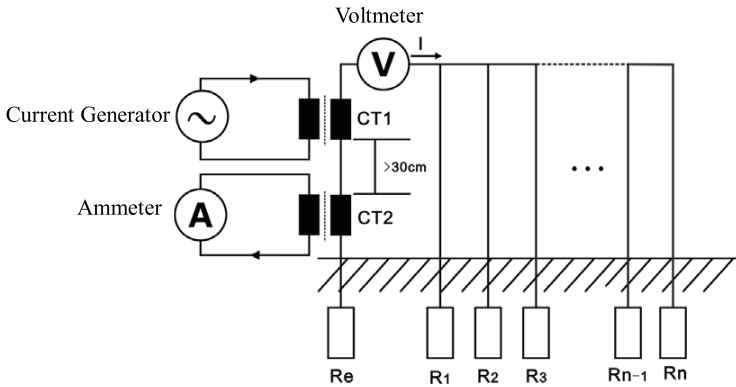

4. Four-pin method (Wenner method) is adopted for measurement of soil resistivity (ρ): The AC current I flows between grounding electrode "E" and current electrode "C(H)", the potential difference "V" between the voltage electrode "P(S)" and the auxiliary grounding electrode "ES" is measured, the potential difference "V" divided by AC current "I" equals the resistance "R" of intermediate two points, the electrode spacing is a (m), the soil resistivity is obtained according to the formula $\rho = 2 a R$ ($\Omega \cdot m$), the spacing between C(H) and P(S) equals that between P(S) and ES (both of them are a), hence the name. To facilitate calculation, please make the electrode spacing " a " much greater than the buried depth " h ", typically $a > 20h$. See the figure below:

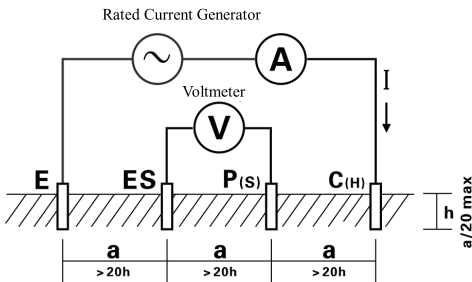

5. For DC resistance testing with 2/3/4-wire method, the rated-current pole-changing method

is adopted (suitable for measurement of equipotential bonding resistance), that is, the DC rated current "I" flows at the measured object "R", the potential difference "V" between both ends of "R" is measured, and the grounding resistance "R" is calculated according to the formula "R=V/I". To ensure the testing accuracy, 4-wire method is adopted and the auxiliary grounding electrode "ES" is added, both ES and E are clamped at the same point of measured object in actual testing.

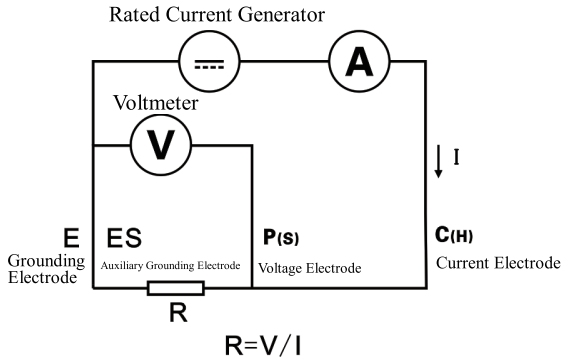

6. The operating errors (B) for the methods above are the errors obtained under the rated operating conditions, the operating errors (B) are calculated and obtained from the inherent error (A) and variable error (Ei) of the tester.

$$B = \pm (|A| + 1.15 \times \sqrt{E_2^2 + E_3^2 + E_4^2 + E_5^2})$$

A: Inherent error

E2: Variation caused by change of supply voltage

E3: Variation caused by temperature change

E4: Variation caused by change of interference voltage

E5: Variation caused by resistance of contact electrode

7. The AC leakage current is measured by the rectifying the average value.

8. The grounding voltage is measured by the rectifying the average value.

VII. Operating Instructions

1 Power On/Off

Power on/off the tester through the functional rotary switch, set the switch at "OFF" to power off the tester. The tester will power off automatically after it is turned on for 15 minutes, please turn the switch to "OFF" after the tester powers off automatically, and then restart the tester.

2 Check the Battery Voltage

If the LCD displays low battery symbol " " after the tester powers on, that indicates battery power is insufficient. Please replace the battery according to the instructions. Only when the battery power is sufficient can the measurement accuracy be guaranteed.

3 Simple 2-Wire Method

2-wire testing method: It is a simple measurement method without the use of auxiliary grounding rod, employing the grounding electrode with minimum grounding resistance to serve as auxiliary grounding electrode, and using two simple testing leads to connect (that is, short-circuit C(H) and P(S) ports, and short-circuit E and ES ports, as shown in the figure below). Metal water pipes, buried metal objects (i.e. fire hydrant), common grounding of commercial power system, building lightning-protection grounding electrode and others can be used to replace auxiliary ground rods (C(H) and P(S)). Please remove the oxide layer at the connection point of auxiliary grounding conductor of selected metal. See the connection diagram below, the operation of the tester is same with 4-wire testing.



If the grounding of commercial power system is used as auxiliary grounding electrode when performing measurement, please first be sure that the auxiliary grounding electrode is the grounding electrode of commercial power system, otherwise the circuit breaker may be started.

When measuring grounding resistance with simple 2-wire method, please select grounding conductor with low re value as auxiliary grounding electrode so that the reading gets closer to the real value. Metal water pipe and metal fire hydrant are priority selections as auxiliary grounding electrode.

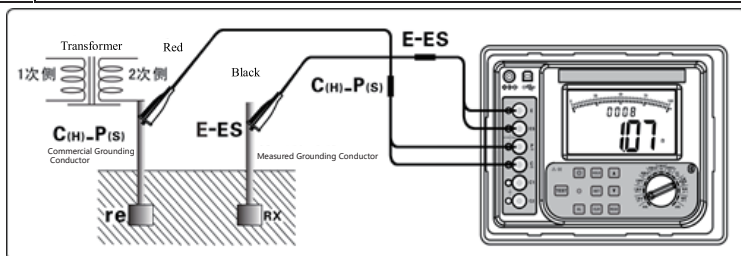

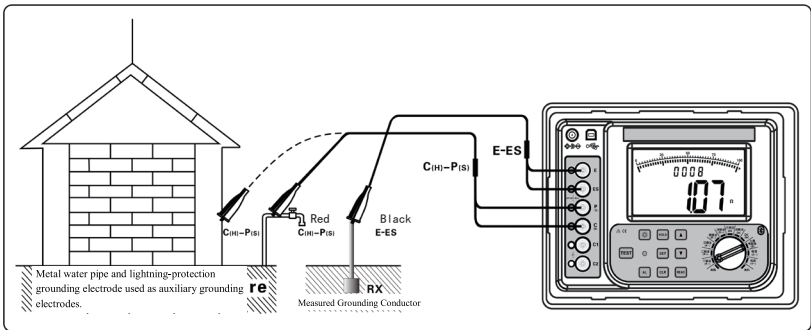

For grounding resistance measurement with simple method: The reading = Grounding resistance of measured grounding conductor + Grounding resistance of commercial grounding conductor, that is:

$$R = RX + re$$

Where:

R is the reading

RX is the grounding resistance of measured grounding conductor

re is the grounding resistance of commercial grounding conductor

So, the grounding resistance of measured grounding conductor is:

$$RX = R - re$$

4. 3-Wire Method

Short-circuit the ES and E ports of the tester as the figure below, hence the name. The operation of the tester with 3-wire method is same with 4-wire testing. The 3-wire testing cannot eliminate the effect of wire resistance change on the measurement, the effect of contact resistance change between tester and test lead on the measurement, and the effect of contact resistance change between test lead and auxiliary ground rod on the measurement. Please remove the oxide layer on the surface of measured grounding conductor before measurement.

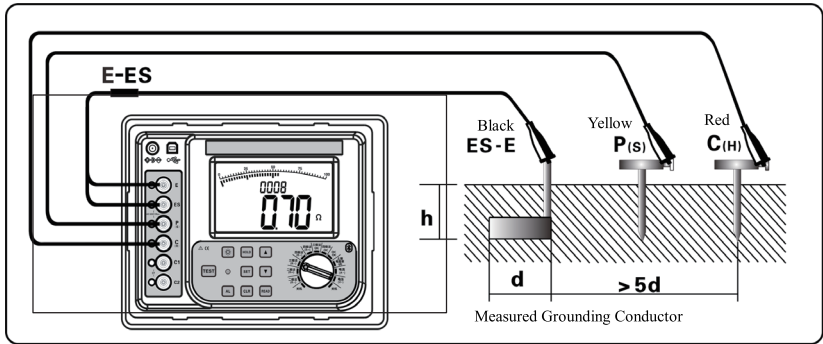

5 4-Wire Precision Method



Before performing grounding resistance test, please first confirm the voltage to ground of the grounding lead, that is, the voltage between C(H) and E or between P(S) and ES must be lower than 20V, if the voltage to ground is greater than 5V, the tester will display the symbol **NOISE**, and measurement error may occur, please power off the equipment of the measured grounding conductor, and then conduct grounding resistance test after the voltage to ground decreases.

The 4-wire testing can eliminate the effect of contact resistance between the measured grounding conductor, auxiliary ground rod, testing clamp, input port (there is dirt or rust usually) of tester on the measurement, and can eliminate the effect of wire resistance change on the measurement, which makes it better than 3-wire testing.

As shown in the figure below, starting from the measured object, bury the auxiliary ground rods (P(H) and C(H)) into the ground respectively in a straight line, and connect the test leads (black, green, yellow, red) from E, ES, P(S), C(H) ports with the measured grounding electrode “E”, auxiliary voltage electrode “P(S)” and auxiliary current electrode “C(H)” accordingly.



The distance between the measured grounding conductor “E” and the current electrode “C(H)” should be 5 times of the buried depth (h) of the measured grounding conductor, or 5 times of the length (d) of buried electrode of the measured grounding conductor.

For measurement of overall grounding resistance of complex grounding system, the distance of d is the distance of maximum diagonal line of the grounding system. Do not twist the test leads when performing test, otherwise the testing accuracy can be affected.

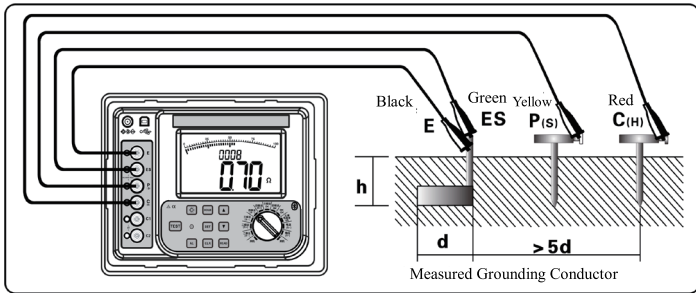

For separate multipoint grounding system or large-scale grounding grid, test leads with a length of 50m or more can be selected for testing, as shown in the figure below:

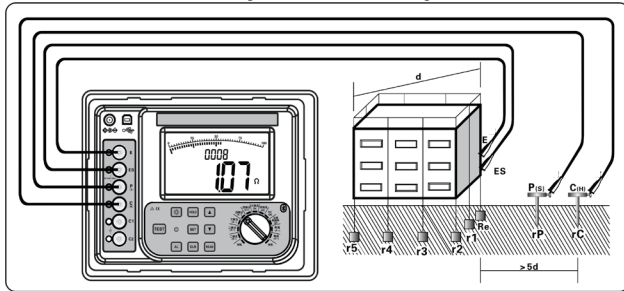

$R = r1 \parallel r2 \parallel r3 \parallel r4 \parallel r5 \parallel r6 \dots \parallel rn$ ($r1 \dots rn$ are separate grounding points)

R: The reading

$r1 \dots rn$: Separate grounding points

rC : The resistance to ground of auxiliary current electrode "C(H)"

rP : The resistance to ground of auxiliary voltage electrode "P(S)"

After connecting the test leads, turn the functional knob to corresponding position to enter grounding resistance mode, and then press **TEST** button to start the test, there are countdown indication and testing progress indication during testing.

After the test is completed, press **SET** button to view the grounding resistance " rC " of auxiliary current electrode "C(H)" and the grounding resistance " rP " of auxiliary voltage electrode "P(S)", after rC and rP are displayed, the tester will return automatically to display the measured grounding resistance "R".

As shown in the figure below, the measured grounding resistance is 2.05 Ω and the tester has stored 8 groups of data; the grounding resistance “rC” of auxiliary current electrode “C(H)” is 0.36k Ω ; the grounding resistance “rP” of auxiliary voltage electrode is 0.27k Ω

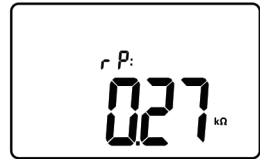
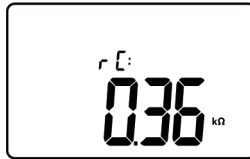
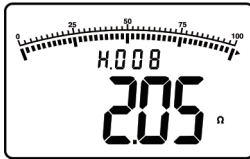

6 4-Wire Selection Method



Before performing grounding resistance test, please first confirm the voltage to ground of the grounding lead, that is, the voltage between C(H) and E or between P(S) and ES must be lower than 20V, if the voltage to ground is greater than 5V, the tester will display the symbol **NOISE**, and measurement error may occur, please power off the equipment of the measured grounding conductor, and then conduct grounding resistance test after the voltage to ground decreases.

The 4-wire testing can eliminate the effect of contact resistance between the measured grounding conductor, auxiliary ground rod, testing clamp, input port (there is usually dirt or rust) of tester on the measurement, and can eliminate the effect of wire resistance change on the measurement, which makes it better than 3-wire testing.

As shown in the figure below, starting from the measured object, bury the auxiliary ground rods (P(S) and C(H)) into the ground respectively in a straight line, and connect the test leads (black, green, yellow, red) from E, ES, P(S), C(H) ports with the measured grounding electrode “E”, auxiliary voltage electrode “P(S)” and auxiliary current electrode “C(H)” accordingly. Insert the blue and black plugs of current clamp (CT2) into C1 and C2 ports respectively, and then clamp the down lead of the measured grounding conductor through the current clamp. Please pay attention to the direction of the clamp, only when the current flows in from the front side of the clamp can the measurement accuracy be guaranteed.



Before measuring grounding resistance, please confirm the value of leakage current of grounding wire, if the current of grounding wire is greater than 100mA and less than 2A, then measurement error may occur, for such case, please power off the equipment of the measured grounding conductor so that the leakage current of grounding wire decreases. Be sure that the current must flow into the current clamp from the front side of the clamp, otherwise grounding resistance measurement cannot be performed normally. If the LCD displays the symbol “”, that indicates the current signal received by CT2 is too weak, please check if there is any issue such as clamping not in place, clamping reversely, incorrect clamping direction, poor contact with auxiliary pile, etc.

The current signal received by CT2 flows upward from the ground, the current flows in from the front side of CT2, clamp the grounding wire with “CT2” mark facing the ground.

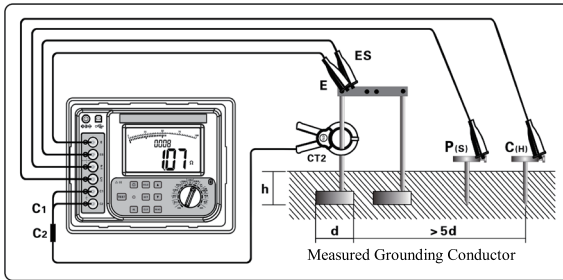

After connecting the test leads, turn the functional knob to “” position to enter grounding resistance test mode, and then press “**TEST**” button to start the test, there are countdown indication and testing progress indication during testing. After the test is completed, the LCD will display the grounding resistance “R” of the measured grounding conductor, as shown in the figure above.

For multipoint grounding system or large-scale grounding grid, test lead with a length of 50m or more can be selected. As shown in the figure below, the measurement result is the measured grounding resistance of R_e , which is not subject to the grounding resistances of $r_1, r_2, r_3, r_4, r_5...$

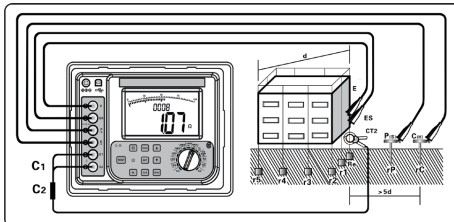

As shown in the figure below, for measurement of grounding resistance of pylon, the grounding resistance “ R_e ” of pylon can be measured accurately with 4-wire selection method when not tripped, but, if with traditional 3- or 4-wire method when not tripped, the measurement result is the resistance measured under the condition that R_e is connected with R_1 , R_2 , R_3 in parallel, if R_e is faulty and the resistance is low after R_1 , R_2 , R_3 are connected in parallel, it is difficult to find out the fault with traditional 3- or 4-wire method, thus the fault is neglected easily.

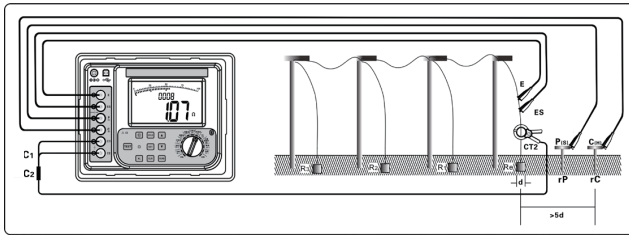

7. Single-Clamp 3-Wire Selection Method

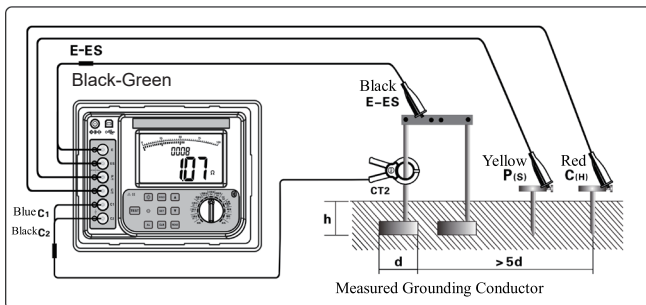

As shown in the figure below, short-circuit the ES and E ports, the operation of the tester is same with 4-wire selection method. The 3-wire selection method cannot eliminate the effect of wire resistance change on the measurement, the effect of contact resistance change between tester and test leads on the measurement, and the effect of contact resistance change between test leads and auxiliary ground rod on the measurement. Please remove oxide layer on the surface of measured grounding conductor before measurement.





8. Double-Clamp Method

Double-clamp method is suitable for measuring separate multipoint grounding system, as shown in the figure below, the measurement of grounding resistance of multipoint grounding system is performed without the need of ground pile. Connect the red and black plugs of CT1

with C(H) and E ports respectively, and connect the blue and black plugs of CT2 with C1 and C2 ports respectively, then clamp the measured loop with CT1 and CT2, please be sure that the direction of CT1 is same with that of CT2, and the distance between CT1 and CT2 shall be greater than 30cm. Do not interchange CT1 and CT2, otherwise it may cause measurement error.

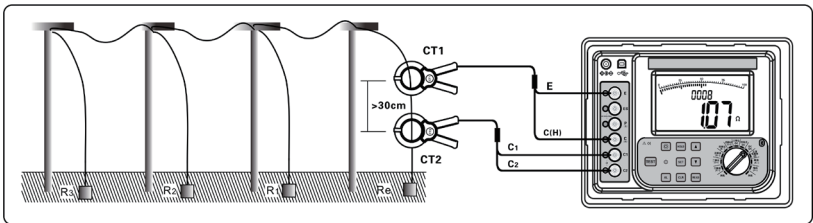
	<p>Before measuring grounding resistance, please confirm the value of leakage current of grounding wire, if the current of grounding wire is greater than 100mA, then measurement error may occur, for such case, please power off the equipment of the measured grounding conductor so that the leakage current of grounding wire decreases. Be sure that the current must flow into the current clamp from the front side of the clamp, otherwise grounding resistance measurement cannot be performed normally. If the LCD displays the symbol “”, that indicates the current signal received by CT2 is too weak, please check if there is any issue such as clamping not in place, incorrect clamping direction, over high loop resistance, or open circuit.</p>
---	---



After connecting the test leads, turn the functional knob to “” position to enter grounding resistance test mode, and then press “**TEST**” button to start the test, there are countdown indication and testing progress indication during testing. After the test is completed, the LCD will display the grounding resistance of the measured grounding conductor, that is, $R=R_e+R_1//R_2//R_3$, if $R_1//R_2//R_3 \ll R_e$, R equals R_e approximately.

9. Soil Resistivity Testing

The soil resistivity (ρ) is an important factor to determine the grounding resistance of grounding conductor. The soil resistivity varies depending upon the soil properties. The resistivity changes significantly due to different temperatures and water contents even for the same type of soil.

Hence, so as to design grounding device on a correct basis and make the designed grounding device meet the actual need, the soil resistivity testing must be performed.

Soil resistivity testing is performed with four-pin method (Wenner method).

Calculate the soil resistivity (ρ) according to the formula $\rho = 2 \frac{R}{a} a^2$, the unit is $\Omega \cdot m$, where,

a = electrode spacing

R = soil resistance between P(S) and ES electrodes

Four-pin method (Wenner method): Connect test leads as shown in the figure below. Bury the auxiliary ground rods (C(H), P(S), ES, E) into the ground respectively in a straight line, connect the test leads (red, yellow, green, black) from C(H), P(S), ES, E ports with the measured auxiliary ground rods (C(H), P(S), ES, E) accordingly. Please pay attention to the spacing and buried depth of auxiliary ground rods.

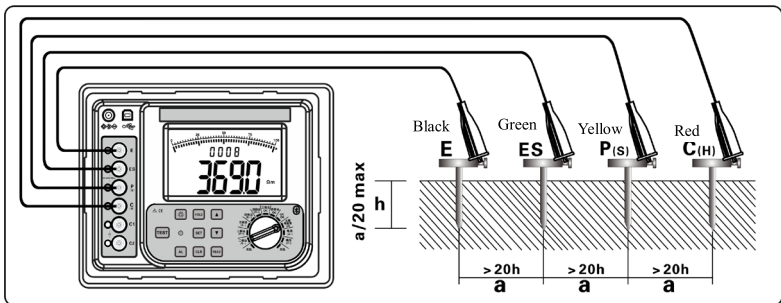

As shown in the figure above, a is the spacing between two ground rods, h is the buried depth, the value measured with Wenner method is the soil resistivity between two ground rods. Check the soil homogeneity by changing the spacing (a), so as to design suitable grounding electrode. Set the spacing between auxiliary ground rods: After connecting the test leads, turn the functional knob to "EARTH" to enter soil resistivity testing mode, long press "SET" button (about 3 seconds) to set the spacing between auxiliary ground rods, short press "SET" button to move the cursor, press "▼" or "▲" button to adjust the present value (the range of a : 1m~100m), long press "SET" button again to save the set a and return to the soil resistivity testing mode.

After completing the setting of a , press "TEST" button in soil resistivity testing mode to start the test, there is countdown to indicate the testing progress. Stable soil resistivity will be displayed

after test.

As shown in the figure below, the measured soil resistivity is 53.38 Ωm , 157 groups of data have been stored. When "SET" button is pressed once, the grounding resistance "rC" of auxiliary current electrode "C(H)" and the grounding resistance "rP" of auxiliary voltage electrode "P(s)" will be displayed. then the measured soil resistivity " " will be displayed.



10. DC Resistance Testing

DC resistance testing is used in equipotential bonding resistance test, test of resistance between metal components, etc. The 4-wire testing can eliminate the effect of contact resistance between the testing clamp, input port (there is dirt or rust usually) of tester on the measurement, and can eliminate the effect of wire resistance change on the measurement, which makes it better than 2-wire testing.

To measure the connection resistance between the equipment and grounding conductor, please connect the test leads (black, green, yellow, red) with the ports (E, ES, P(H), C(H)) respectively, clamp the leading-out end of grounding wire of the equipment with E and ES, and clamp the down lead near the ground with P(S) and C(H), as shown in the figure below:

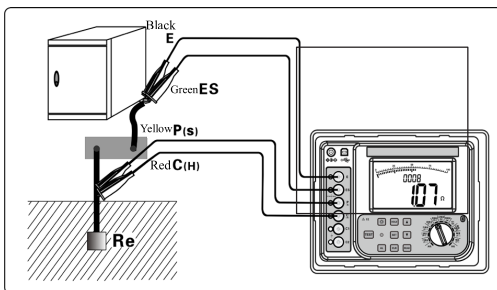

After connecting test leads, turn the functional knob to "R----" to enter DC resistance testing mode, press "TEST" button to start the test, there are countdown indication and progress bar indication during test. After the testing is completed, the equipotential bonding resistance "R" between the measured equipment and grounding conductor will be displayed.

11 AC Current Testing

Insert the blue and black plugs of CT2 into C1 and C2 ports respectively, and clamp the measured conductor by CT2, as shown in the figure below:

	The current of measured circuit shall not be over 600A. The test is performed by current clamp only. Do not connect current signal with the jack of the tester directly, otherwise, it may damage the tester.
	Please measure current with "CT2" current clamp, error can occur if the current clamp is interchanged.
	Clamp the live wire when measuring load current. Clamp the live and neutral wires or clamp the grounding wire when measuring leakage current.
	Prevent interference from nearby electromagnetic fields when measuring leakage current.

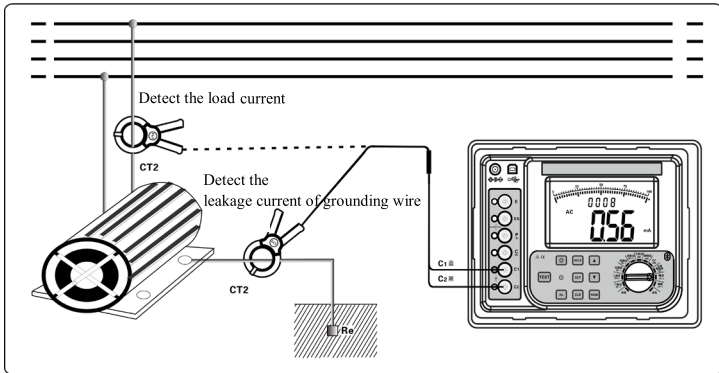

After connecting the current clamp, when setting the functional knob to "Iclamp", the tester will enter current testing mode, the LCD will display RMS current, and the bar graph will indicate the amplitude change.

12 Grounding Voltage Testing

	One piece of auxiliary ground rod is needed for grounding voltage testing.
	If the tester connects with the ground through test lead and auxiliary ground rod, then other test leads from the ports of the tester are not allowed to connect with the L and N wires of commercial power source, otherwise, current leakage will occur and circuit breaker will be started, which can pose a risk.
	Do not test grounding voltage over 100V.
	Do not use the tester in commercial voltage testing, otherwise it may cause damage to the tester.

Grounding voltage is the potential difference between zero-potential point and the casing of grounding equipment, grounding wire, grounding conductor and others when grounding fault occurs at electrical equipment. The ground is taken as a reference point and a zero-potential point.

One piece of auxiliary ground rod is needed for grounding voltage testing, please distinguish grounding voltage testing from AC voltage testing. After the tester, auxiliary ground rod and test leads are connected, turn the functional knob to "EARTH VOLTAGE" to start testing, the test result will be displayed on the LCD.

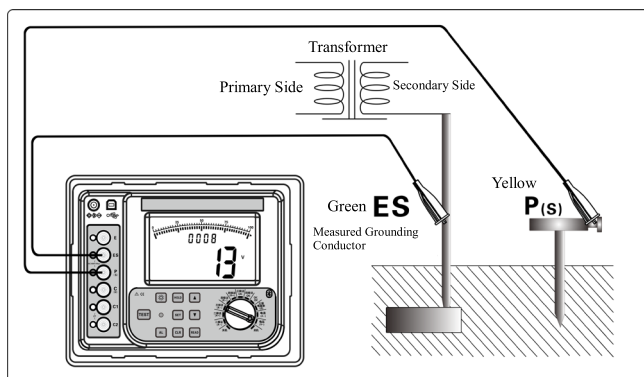

13 Backlight Control

When the tester is powered on, press "" button to turn on/off the backlight, the backlight function is used in dim environment. The backlight is off by default every time the tester is turned on.

14. Alarm Setting

After the tester is powered on, turn the functional knob to corresponding position, short press "**AL**" button to enable or disable the alarm function, long press "**AL**" button (about 3 seconds) to set alarming threshold, press "**▲**" or "**▼**" button to adjust the present value, short press "**AL**" button to move the cursor, then long press "**AL**" button to save and exit. If the measured value is greater than the alarming threshold and the alarming function has been enabled, the symbol "**!!!**" will flash and the meter will make "Beep—Beep--Beep" sounds as an alarm.

15. Data Hold/Storage

The tester will store a group of data every time when the testing is completed. In testing mode, when "**HOLD**" button is short pressed, the displayed data will be held, the symbol "**HOLD**" and the group numbering will be displayed, short press "**HOLD**" again to unlock the data. As shown in the figure below, the soil resistivity of 53.38 Ωm is held as the 28th group of stored data.

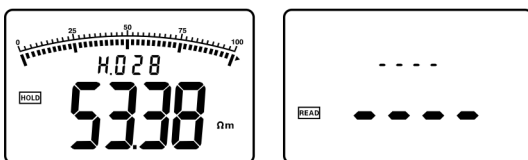

16. Data Viewing/Deletion

In testing mode, short press "**READ**" button to enter data viewing mode, press "**▲**" or "**▼**" button to select array numbering with the step value at 1, press and hold "**▲**" or "**▼**" button to select array numbering with the step value at 10, if the present data are grounding resistance data or soil resistivity data, press "**SET**" button to view the values of rC, rP and a, press "**READ**" again to exit data viewing mode.

The LCD will display "----" if there is no storage data, see the figure above.

In data viewing status, press "**CLR**" button to enter data deletion mode, press "**▲**" or "**▼**" button to select "no" or "YES", if "no" is selected and then "**CLR**" button is pressed, that data will not be deleted and the tester will return to data viewing status, if "YES" is selected and then "**CLR**" is pressed, the stored data will be deleted, after deletion, the LCD will display "----" as shown in the figure above. Please note that all stored data will be deleted at a time and cannot be resumed if "YES" is selected and then "**CLR**" is pressed.

17. Data Uploading

Install the USB driver and uploading software before use. Please download the software from the official website of Uni-Trend.



It is forbidden to connect with computer to view the data when performing test, otherwise the grounding voltage can damage the computer or the tester.

The data stored in the tester can be uploaded to computer. Please connect the computer with USB cable, turn on the tester, and then operate the data software, if the serial port is opened and the connection is completed, then the stored data can be read, uploaded to and saved in the computer. The data software has multiple functions such as data accessing, viewing, storage, printing, etc.

VIII. Battery Charging



The charging time is 2 hours typically. Do not charge the tester for over 10 hours.

If the tester is not used for a long time, please charge the battery once every one or two months.

The indicator light of the charger is lit up red when charging and green when fully charged.

The tester must be charged with dedicated charger.

1. When the battery voltage drops to DC $7.2V \pm 0.1V$, the tester will display the symbol "" to indicate low battery, please charge the battery in time, the indicator light of the charger is lit up red when charging and green when fully charged.
2. Power off the tester, make sure that the tester in power-off state, and charge the tester with the charger through mains power.
3. Please keep the charger well after the tester is fully charged.

IX. Packing List

Item	Quantity (pcs)
Tester	1
Carrying bag	1
Auxiliary grounding rod	4
Test lead	4
Simple test lead	2
Current clamp	2
USB cable	1
Dedicated charger	1
User manual	1

The company is not responsible for other losses caused by use.

The content of this user manual cannot be used as a reason for using the product for special purposes.

The company reserves the right to modify the contents of the user manual. If there are changes, no further notice will be given.