



I.S.A. Istrumentazioni Sistemi Automatici S.r.l.
Via Prati Bassi 22 - 21020 Taino (VA) - ITALIA
tel +39 0331 956081 - fax +39 0331 957091
e-mail: isa@isatest.com - www.isatest.com

DATE:08/07/2022

DOC.SIE10169

REV.18

**CIRCUIT BREAKER ANALYZER
AND MICROOHMMETER
MOD. CBA2000**

APPLICABLE STANDARDS	4
1 INTRODUCTION	5
2 CHARACTERISTICS	8
2.1 COIL DRIVING CIRCUITS	8
2.2 MAIN CONTACT INPUTS	8
2.3 AUXILIARY INPUTS AND OUTPUTS.....	8
2.4 INPUTS TIMING.....	9
2.5 ANALOG INPUT	9
2.5.1 <i>Coil currents</i>	9
2.5.2 <i>High voltage analog inputs</i>	9
2.5.3 <i>Low voltage analog inputs</i>	10
2.5.4 <i>Digital transducers</i>	10
2.6 TIME MEASUREMENT TRIGGERS.....	10
2.7 PROGRAMMABLE SEQUENCES	11
2.8 STATIC RESISTANCE MEASUREMENT (OPTIONAL).....	12
2.9 DYNAMIC RESISTANCE MEASUREMENT (OPTIONAL)	12
2.10 TEST SET CONTROL	12
2.11 DATA MANAGEMENT	13
2.12 PC SOFTWARE.....	13
2.13 MENU SELECTIONS	14
2.14 OTHER CHARACTERISTICS.....	14
3 OPTIONS	15
3.0 CONNECTORS ON MAIN CONTACTS INPUTS.....	15
3.1 STATIC AND DYNAMIC RESISTANCE MEASUREMENT.	15
3.2 FOUR COIL COMMANDS.....	15
3.3 ADDITIONAL MAIN AND AUXILIARY INPUTS.....	15
3.5 EXTERNAL PRINTER, CODE PII14102.	15
3.6 INTERNAL PRINTER.....	15
3.7 MINIMUM TRIP COIL TESTER	16
3.8 BASIC CONNECTION CABLES SET.....	17
3.9 LONG CONNECTION CABLES; CODE PII81169 OR PII45266.....	21
3.10 TRANSIT CASE.....	22
3.11 SOFT PROTECTION BAG.....	22
3.12 POSITION TRANSDUCERS.....	23
3.12.1 <i>Analog transducers</i>	23
3.12.2 <i>Digital transducers</i>	24
3.12.3 <i>Adaptors for mounting kit</i>	25
3.13 HALL EFFECT CLIP-ON TRANSFORMER FOR I MEASUREMENTS, CODE PII29166.	26
3.14 AC CURRENT CLAMP, CODE PII88169.....	26
3.15 PRESSURE TRANSDUCER, CODE PII13169.	27
4 PROTECTIONS	28
APPENDIX A: MENU SELECTIONS	29

APPLICABLE STANDARDS

The test set conforms to the EEC directives regarding Electromagnetic Compatibility and Low Voltage instruments.

A) Electromagnetic Compatibility:

Directive no. 2004/108/EC. Applicable Standard : EN61326-1 + A1 + A2.

EMISSION

- EN 61000-3-2 + A2: Harmonic content of power supply. Acceptable limits: basic.
- EN 61000-3-3 + A1: Limitation of voltage fluctuations and flicker. Acceptable limits: basic.
- CISPR16 (EN 55011 class A): Limits and measurement methods of radio-electric disturbances for industrial, medical and scientific instruments at radio-electric frequencies.

Acceptable limits for conducted emission:

- . 0.15-0.5 MHz: 79 dB pk; 66 dB avg.
- . 0.5-5 MHz: 73 dB pk; 60 dB avg.
- . 5-30 MHz: 73 dB pk; 60 dB avg.

Acceptable limits for radiated emission:

- . 30-230 MHz: 40 dB (30 m)
- . 230-1000 MHz: 47 dB (30 m)

IMMUNITY

- EN 61000-4-2 + A1 + A2: Immunity tests for ESD. Test values: 8 kV in air; 4 kV in contact.
- EN 61000-4-3 + A1; Immunity tests for radio frequency interference. Test values ($f = 900 \pm 5$ MHz): field 10 V/m, modulated AM 80%; 1 kHz
- EN 61000-4-4; Immunity tests for high speed transients (burst). Test values: 2 kV peak; 5/50 ns.
- EN 61000-4-5 + A1; Immunity tests for surge. Test values: 1 kV peak differential mode; 2 kV peak common mode; 1.2/50 us.
- EN 61000-4-6 + A1: immunity to low-voltage sinusoidal waveform. Test values: 0.15-80 MHz, 10 Vrms, 80% AM 1 kHz.
- EN 61000-4-8 + A1: Immunity tests for low frequency magnetic fields. Test values: 30 Arms/m.
- EN 61000-4-11: Immunity test for power supply drops. Test value: 1 cycle; 100% drop.

B) Low Voltage Directive

- - Directive n. 2006/95/EC. Applicable standard: EN 61010-1. In particular, for a pollution degree 2:
 - Dielectric rigidity 1.4 kV AC, 1 minute.
 - Inputs/outputs protection: IP 2X - EN60529.
 - Operating temperature: - 10 °C to 55 °C; storage: - 20 °C to + 70 °C.
 - Relative humidity : 5 - 95%, without condensing.
 - Vibration: IEC 68-2-6 (20 m/s² at 10 – 150 Hz);
 - Shock: IEC 68-2-27 (15 g; 11 ms; half-sine).
 - Altitude: less than 2000 m.

1 INTRODUCTION

The circuit breaker analyzer and microOhmmeter model CBA2000 is a two-in-one test set.

When used as a circuit breaker analyzer, it allows the off-line testing of the characteristics of all modern MV, HV and EHV circuit breakers. The test set measures CB operation times as they are defined in the IEC standard 62271-100; in particular:

- . Opening time: see 3.7.133;
- . Closing time: see 3.7.136;
- . O-C time: see 3.7.139;
- . C-O time: see 3.7.143;
- . Minimum trip duration: see 3.7.146;
- . Minimum close duration: see 3.7.147.

It is possible to configure all the test parameters “open free” and customize sequencies. CBA2000 measures simultaneously the circuit breaker time delays, displacements, speeds and coil currents.

When used as a microOhmmeter, it allows measuring the contact resistance of the circuit breaker contact, or also of joints or other circuit parts. It allows also to perform the dynamic test of the contact resistance, that is to record and display how does the contact resistance change while it is closing: this allows detecting hidden defects, that are otherwise impossible to be diagnosed.

The instrument performs the following features:

Test set control: via keypad plus selection knob plus dedicated keys, and a large transfective LCD display (320 x 240 pixels; view area 122 x 92 mm).

- . Optional internal thermal printer 58 mm wide or external thermal printer 112 mm wide.
- . Huge recording capability: 256 Mb (typically 500 results).
- . Capability to transfer results directly to an USB pen drive
- . USB and RS232 interface for data communication with the PC.
- . Two driving coil circuits (O+C); 4 optionally available. The coil current is independently measured on all outputs, with three current ranges.
- . Three sets of two main contact sensing circuits (two chambers tests); optionally, three sets of four or six main contact sensing circuits (four or six chambers test).
- . Capability of controlling up to four test sets, for tests of CB's with up to 24 chambers per phase.
- . Test of the main contact and of the pre-insertion resistor.
- . Four auxiliary input circuits; optionally, 8 or 12.
- . For the main and event inputs, measurement of delays with respect to coil currents or other references.
- . The Open or Closed state of main and event inputs is displayed by a light: thanks to these lights, the status of the circuit breaker is continuously monitored.
- . Eight analog input measurement circuits, to be selected among the following:
 - Coil current measurement: minimum 2, maximum 4;
 - Two high AC or DC voltage measurement: up to 500 VDC or 350 V AC, for the measurement of the standby battery or of the motor supply;
 - Four low DC voltage measurement inputs, for the measurement of position transducers stroke and speed, or of the pressure, or other low-level parameters.
- . DC voltage source for potentiometer transducers polarization.
- . One auxiliary relay output, programmable.
- . Static resistance measurement; test current 200 A, 100 A or 20 A.
- . Dynamic contact resistance test; test current 200 A, 100 A or 20 A.

- . Many triggers can start the recording.
- . Capability of generating or sensing a trigger, so that a number of units can operate at the meantime.
- . All possible test sequences are programmable.
- . Test result is shown on the display and it is possible to zoom and compare in the same graph the open and/or close time of the different breaks of the CB under test, the coils current open and/or close, the resistance and so on. The results are also displayed in table.
- . Capability of storing and recalling both test settings and test results.
- . The software TDMS (that operates with WINDOWS 7 up) is included: it allows analysing test results, adding notes, saving into a data base and so on. It allows also to store and recall test settings.

NOTE: WINDOWS is a trademark of MICROSOFT inc

All circuits have been designed to ensure safe operation in the noisy environment of MV, HV and EHV substations.

The instrument is housed in a transportable aluminium box, that is provided with removable cover and handles for ease of transportation.

The following table lists the key new features of CBA2000 with respect to CBA1000.

PERFORMANCE	CBA2000	CBA1000
COIL DRIVING CIRCUITS	2; 4 OPTIONAL	2; 4 OPTIONAL
MAIN CONTACT INPUTS	3 GROUPS OF 2; OPTIONAL :3 GROUPS OF 4 or 3 GROUPS OF 6	3 GROUPS OF 2
MASTER-SLAVE CONNECTION	ONE MASTER + 3 SLAVE	ONE MASTER + 3 SLAVE
AUXILIARY INPUTS	2 GROUPS OF 2; OPTIONAL : 4 GROUPS OF 2 or 6 GROUPS OF 2	2 GROUPS OF 2
AUXILIARY OUTPUT	ONE RELAY CONTACT : 8 A, 250 V	NOT AVAILABLE
ANALOG INPUTS	10 IN ALL: - 2 (4) COIL CURRENTS; - 1 CONTACT RESISTANCE MEASUREMENT; - 2 HIGH VOLTAGE, 500 V DC; - 3 LOW VOLTAGE, 10 V DC.	6 IN ALL: - 2 (OR 4) COIL CURRENTS; - 1 UP TO 500 V DC; - 1 UP TO 5 V DC.
Digital inputs option	3; RS422	NO
USB pen drive	YES	NO
DIMENSIONS	485 (W) * 365 (D) * 240 (H) mm	400 (W) * 300 (D) * 240 (H) mm
WEIGHT	15 kg	10 kg

The following pictures show the CBA2000 front panel, that can be provided in two different versions: with banana plugs or optionally with connectors on main contacts.

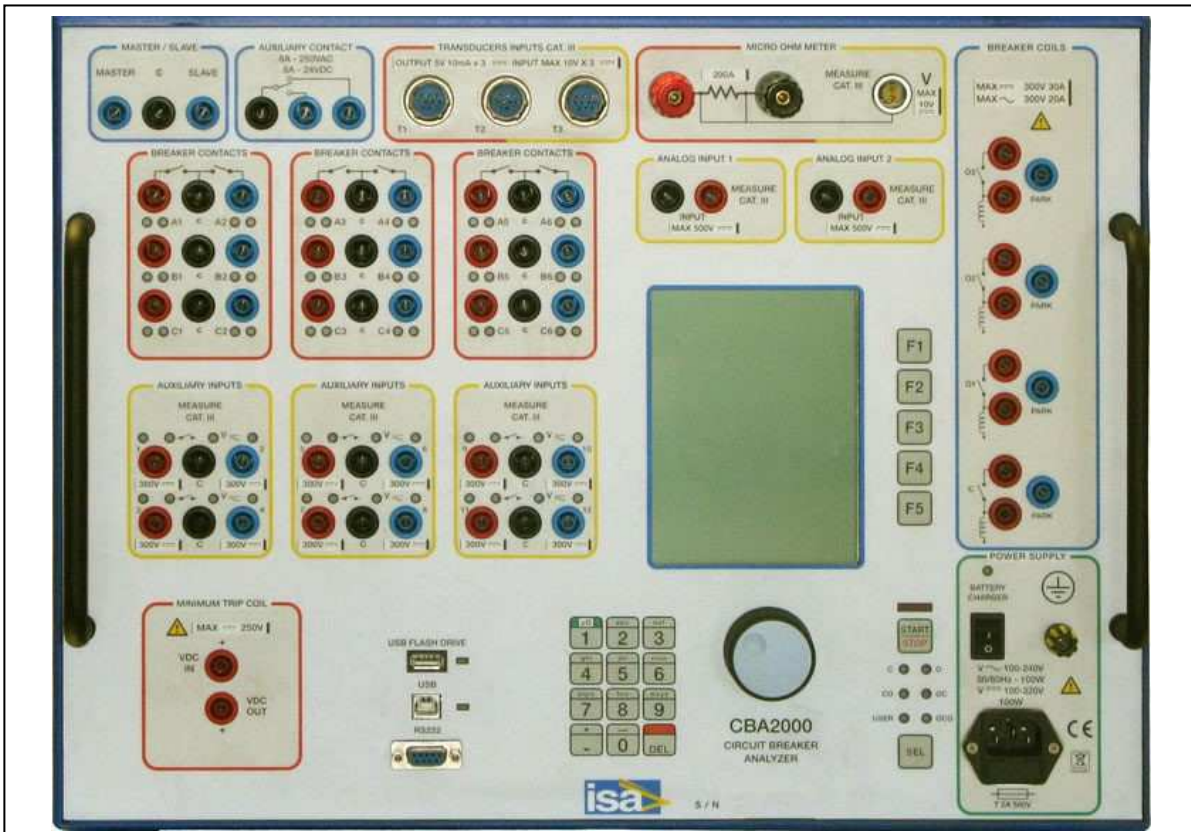

CBA2000 with banana plugs on main contacts

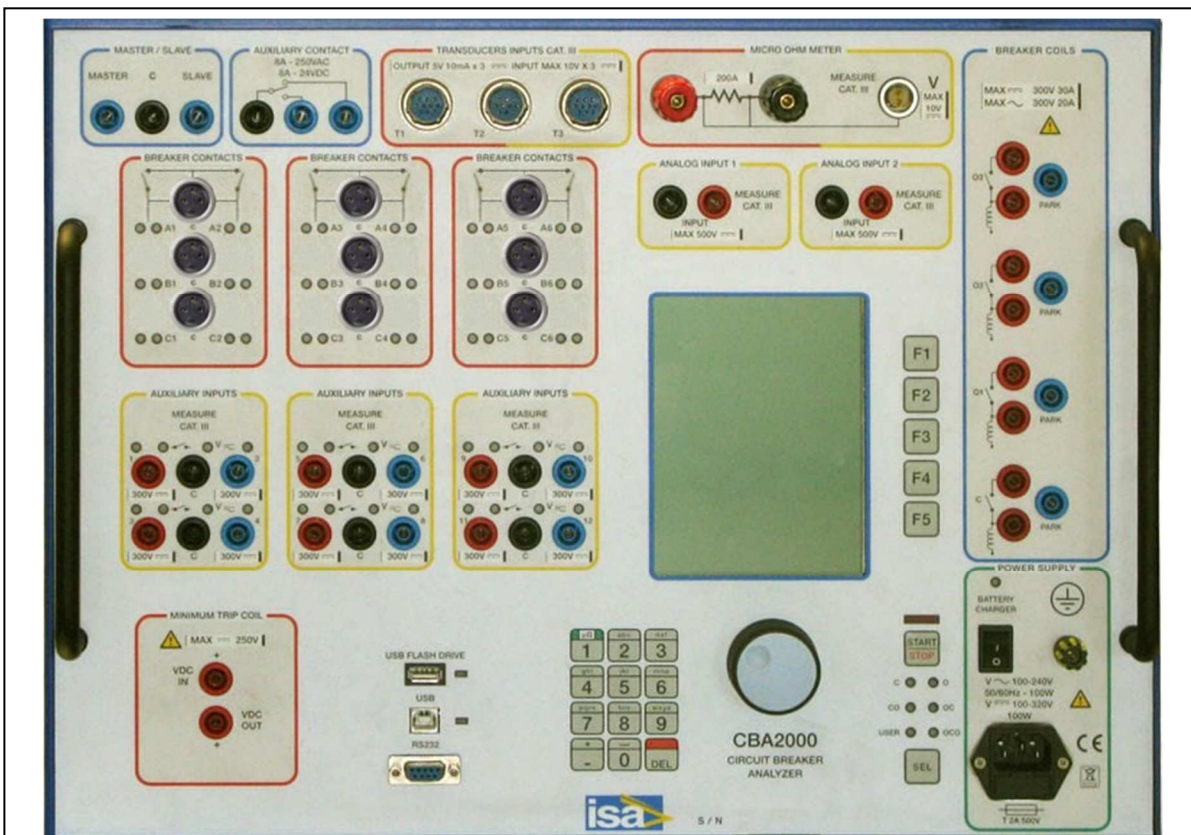

CBA2000 with connectors on main contacts

2 CHARACTERISTICS

2.1 COIL DRIVING CIRCUITS

- . Number of circuits: two; optionally four.
- . Type of driver: electronic; it ensures superior timing control.
- . Driver characteristic: 300 V DC max; 30 A DC max; 300 V AC max; 20 A AC max.
- . Operating time accuracy: 0.025% of delay \pm 50 us.
- . Coil current ranges: 2.5; 10; 25 A full scale, user selectable.
- . The coil current is measured by a dedicated circuit, which is enclosed in the test set, so that a single connection is enough to connect the coil and to measure its current.
- . Number of coil current measurement circuits: two (optionally four).
- . In case of four outputs, it is possible to select the single or multiple phase opening.
- . Coil current measurement accuracy: 0.5% of the reading \pm 0.1% of the selected range.
- . Resolution 1 mA , 5mA or 10 mA depending upon the selected range.
- . Connection: via four (optionally eight) safety sockets.
- . Outputs are isolated between them.

2.2 MAIN CONTACT INPUTS

- . Number of main contact inputs: six in all (two per phase), divided in three groups of two each; optionally twelve (four per phase), divided in six groups of two each, or 18, divided in 9 groups of two each.
- . Test of the main contact and of the pre-insertion resistor contact, selectable.
- . The contact is CLOSED when the contact resistance is less than 10 Ohm.
- . The contact is OPENED when the contact resistance is greater than 10 kOhm.
- . Pre-insertion resistor contact range: 20 Ohm to 10 kOhm. Between 10 and 20 Ohm the contact should be detected closed or resistive depending upon internal analog thresholds.
- . Contact test voltage: 24 V; test current: 50 mA.
- . Each input group is isolated with respect to the others.
- . Connection: via nine safety sockets (optionally eighteen or twenty seven safety sockets) or three connectors (optionally six or nine connectors).
- . When a main contact is closed, the corresponding light on the front panel turns on.

2.3 AUXILIARY INPUTS AND OUTPUTS

- . Number of auxiliary inputs: four, divided in two groups of two each. Optionally, eight or twelve, divided in four or six groups of two inputs. A contact is detected as closed if the current flowing is at least 1 mA. The detection of the status (open or close) is based on current and the contact resistance is not taken in account.
- . Each two inputs are galvanically isolated with respect to the others.
- . Capability of testing dry contacts:
 - contact test voltage: >14 V
 - short circuit test current: >1.5 mA
- . Capability of testing wet contacts:
 - input voltage: up to 300 V
 - close status : > 20 V , open status : < 8 V
 - input current: > 1.5 mA.
- . Contact selection can be different on the groups.
- . Connection: via 6 (optionally 12 or 18) safety sockets.
- . When an auxiliary input is closed, the corresponding light on the front panel turns on
- . One relay auxiliary output. Contact characteristics: 8 A, 250 VDC. The contact operation can be timed with respect to test start.

2.4 INPUTS TIMING

- . Sample rate: from 20 kHz maximum (for recording up to 1s) to 20Hz (for recording up to 1000s). See the table below for more details.
- . Resolution: 0.05 ms to 50ms.
- . Inputs timing accuracy: see the following table.

RANGE	FREQUENCY	RESOLUTION	ACCURACY
1 s	20000 Hz	0.05 ms	0.05 ms \pm 0.025% of the reading
2 s	10000 Hz	0.1 ms	0.1 ms \pm 0.025% of the reading
4 s	5000 Hz	0.2 ms	0.2 ms \pm 0.025% of the reading
10 s	2000 Hz	0.5 ms	0.5 ms \pm 0.025% of the reading
20 s	1000 Hz	1 ms	1 ms \pm 0.025% of the reading
40 s	500 Hz	2 ms	2 ms \pm 0.025% of the reading
100 s	200 Hz	5 ms	5 ms \pm 0.025% of the reading
200 s	100 Hz	10 ms	10 ms \pm 0.025% of the reading
400 s	50 Hz	20 ms	20 ms \pm 0.025% of the reading
1000 s	20 Hz	50 ms	50 ms \pm 0.025% of the reading

2.5 ANALOG INPUT

Number of analog inputs: ten in all, programmable. Common characteristics of analog inputs:

- . Measurement resolution: 16 bit.
- . Measurement accuracy: 0.5% of the reading \pm 0.1% of the selected range.
- . Impedance: more than 200 kOhm.
- . Measurement sampling rate: 20 kHz max.

2.5.1 Coil currents

The two coil current measurements; optionally four, above described are included in the total of ten analog channels.

2.5.2 High voltage analog inputs

- . Number: two, with no common point.
- . Input voltage ranges: \pm 5 V; \pm 50 V; \pm 500 V DC (3.5; 35; 350 V AC), user selected. These ranges allow measuring all AC and DC voltages.
- . Analog input measurement resolution: 16 bit.
- . Analog input measurement accuracy: 0.5% of the reading \pm 0.1% of the selected range, for DC inputs: 1 % of the reading \pm 0.2% of the selected range, for AC inputs.
- . Analog input impedance: more than 200 kOhm.
- . Analog input measurement sampling rate: 20 kHz max.
- . Connection: via four safety sockets.

2.5.3 Low voltage analog inputs

- . Number: three plus one.
- . For all of them, the input voltage range is ± 10 V.
- . Three of them are for transducers measurements or for analog input measurements, and have the same reference point; the fourth one is dedicated to the micro-Ohmmeter.
- . For the three inputs, they can be used for position or pressure transducers, or for analog signal measurements.

When used with position transducers, the software allows the displaying of: positions, strokes, speed (datum point). These measurements are defined by the position of the cursors. In this instance, it is possible to input the transducer stroke, and to set the unit of measurement as millimetres, degrees or inches.

When the transducer movement is 50% of the total transducer length, the position error is 1% of the reading. The error is inversely proportional to the percentage of the transducer movement. When datum points are 25% of the total transducer length, and the corresponding time is 10 ms, the speed accuracy is 3%. The error is inversely proportional to the percentage of the transducer movement and to the movement time.

. When used as analog inputs, the most important use is the monitoring of the secondary current of an energized CB, to perform the first trip test, that is, the measurement of the Open delay while the CB is in service. This test is very important to detect the delay caused by the friction, which sticks the CB that has operated a long time without opening.

- . Connection: three via three multi-pole connectors; the fourth one via a two-way shielded connector.
- . On the same connectors is available a polarizing voltage to supply linear position transducers.
- . Voltage value: + 5 V; maximum output current 30 mA; minimum transducer resistance 170 Ohm. The output has the same reference as the three low voltage analog inputs.

2.5.4 Digital transducers

The digital transducer input allows monitoring up to three digital transducers at the meantime.

- . Maximum input frequency: 50 kHz;
- . Interface: RS422;
- . Accepted transducers: up to 5000 impulses per turn.
- . Connection: by the same three multi-pole connectors used for the analog inputs.

2.6 TIME MEASUREMENT TRIGGERS

The following time measurement trigger options are user selectable:

- . Internal: the time measurement starts as the first Open or Close coil command is issued by the driving circuit. Timing accuracy: 50 μ s.
- . Coil current: the time measurement starts as soon as the first Open or Close coil current exceeds the selected percentage, from 1% to 30%, of the selected current range.
- . Auxiliary input: the time measurement starts when the selected auxiliary input turns ON or changes its state. The trigger can be performed also on a logical combination of auxiliary inputs.
- . Analog input: the time measurement starts when the analog input level crosses (greater than, lower than) the selected threshold.
- . External trigger. The test set features a Trigger Out output and a Trigger In input, that allow synchronizing up to 4 CBA2000's. In this mode, one CBA2000 acts as the Master unit; its Trigger Out output will be connected to all other units, selected as Slave. As the Master starts the test, all other Slave units will measure the timing on Main, auxiliary and analog inputs. Maximum timing

error: 100 us. This feature allows to test circuit breakers with more than two chambers per phase, or to survey more than four auxiliary inputs, or to survey more than one analog input at a time.

2.7 PROGRAMMABLE SEQUENCES

The user can select the following Open and Close sequences:

- . Open: the Open coil is driven. In case of four coils, the selected Open coil phase is driven.
- . Close: the Close coil is driven.
- . OC: In sequence, the Open and Close coils are driven. In case of four coils, the selected Open coil phase is driven.
- . CO: In sequence, the Close and Open coils are driven. In case of four coils, the selected Open coil phase is driven.
- . OCO: In sequence, the Open, the Close and then again the Open coils are driven. In case of four coils, the first Open command is issued on the selected Open coil phase, while the second Open command is issued on all coil phases.

Via the software, it is possible to repeat an OC or CO command up to 9999 times.

These sequences are also selected by means of a dedicated pushbutton; the selected sequence is confirmed by an LED.

For all the above sequences, the user can program the following delays:

- . Open command duration: range 10 ms to 10 s.
- . Close command duration: range 10 ms to 10 s.
- . Open to Close delay: delay range 10 ms to 199.990 s.
- . Close to Open delay: delay range 10 ms to 199.990 s.
- . Recording duration: range 10 ms to 199.990 s.
- . After programming, it is possible to view on the display the sequence timing: this helps avoiding programming errors.

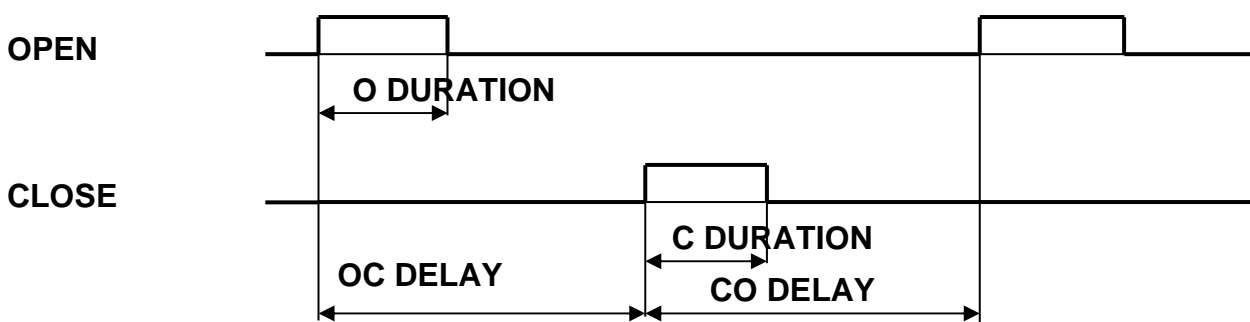

2.8 STATIC RESISTANCE MEASUREMENT (OPTIONAL)

This measurement is performed connecting CBA2000 to the test sample and measuring its resistance. Test samples can be: joints, main contacts and so on. Main contacts resistance is measured in the closed position.

. Test current, resistance measuring range, resolution and accuracy: see the table.

TEST CURRENT	RESISTANCE RANGE	RESOLUTION	ACCURACY
A	mOhm	μ Ohm	
200	0.2	1	2 % of the reading \pm 0.5% of the range
	1	1	2 % of the reading \pm 0.5% of the range
100	1	1	2 % of the reading \pm 0.5% of the range
	10	1	1 % of the reading \pm 0.3% of the range
20	10	1	1 % of the reading \pm 0.3% of the range
	100	1	1 % of the reading \pm 0.2% of the range

. Type of current source: electronic constant current generator, driven by a discharging capacitor.

. Current generation duration: minimum 30 ms, according to the test current and the load.

. Capacitor charging time: 60 s.

. Maximum test voltage: 18 V.

. Test mode selection. With single test, the resistance value is displayed. With Circuit Breaker test, the screen shows a table that collects the measurement of all phases.

. NOTE: during the first 4 ms, the resistance measurement is affected by the connection leads inductance.

2.9 DYNAMIC RESISTANCE MEASUREMENT (OPTIONAL)

With this measurement it is possible to record the main contact resistance during the CB close.

The CB is open prior to test start: CBA2000 issues the Close command; as the contact closes, the test current passes through the contact, and CBA1000 measures the contact resistance variations during the close movement.

. Test current, resistance ranges and other characteristics: as for the static resistance measurement.

. Unlike the static resistance measurement, the test result is not a table of resistance measurements: it is the resistance profile during the test, along with voltage and current profiles.

2.10 TEST SET CONTROL

. The control is local, via keypad, selectors and display: no PC control is necessary.

. Keypad: 12 keys, numeric plus alphabet: it allows inputting all test references. The arrangement is the same as portable phones.

. Two dedicated pushbuttons for test start and sequence selection.

. Numeric encoder with pushbutton for menu selection (see below the selections list).

. Five pushbuttons as menu shortcuts

. As the test is started, a buzzer warns the operator.

. The graphical display has the following main features:

- Type: transfective LCD;
- Pixels: 320x 240;
- Backlight color: white;

- View area: 122 x 92 mm;
- Displays: menu selections prior to test start; then, current waveforms, contact inputs (main – resistance), auxiliary inputs, analog input (those enabled). For dynamic resistance, it is possible to display the resistance profile, along with voltage and current profiles.
- . Memory size: 256 Mbytes (approx. 500 results).
- . Maximum record length: 200 s.
- . Capability of saving and re-calling up to 64 test settings.

2.11 DATA MANAGEMENT

The communication to the PC can be performed via two communication ports:

- . RS232; baud rate 57600;
- . USB.

Test results can be saved into an USB pen memory: this allows transferring all test results to the office without the need of transporting the test set.

2.12 PC SOFTWARE

The dedicated TDMS software has the following main features.

- . Download of test sequences.
- . Download of test results.
- . Test sequences and test results can be viewed, edited in the missing descriptions, saved, printed, exported.
- . Test data can be organized in a data base including all sub-station devices.
- . Possibility of viewing, overlaying and gluing more results, for an easy test result comparison.
- . Possibility to pre-set test sequences and to download them into the test set.
- . Two cursors to select measurement points and intervals.
- . Zoom in and out feature.
- . Pass – fail timing test result analysis.
- . Pass – fail current profile test result analysis.
- . Enhanced measurement features for movement – speed – acceleration control.

The software will be upgraded for free until a new version is released. Upgrading is simple: just connect to the ISA WEB site, and download the latest version. This applies also to the test set resident program.

2.13 MENU SELECTIONS

Appendix A lists the features that are menu selected. The menu is operated by means of the MENU control knob, which incorporates a switch. The menu is entered pressing the knob and selecting the item moving the knob. Once the item has been found and programmed, pressing the arrow the menu moves back, so that other programming can be performed.

After test start, measurements are displayed in the corresponding window. Pressing the knob it is possible to return to menu selections and modify them, and then it is possible to return to the measurements window.

Any setting can be saved to and recalled from the memory, with a line of text description. At power-on, the default one is displayed: it can also be recalled as necessary. Settings are permanently stored in the memory; new settings can be written to the same address after confirmation. For normal mode operation it is possible to recall the standard setting, that cannot be modified.

During the test, test results can be stored in the memory, according to selections.

2.14 OTHER CHARACTERISTICS

- . Mains supply:
 - .. From 85 to 265 V AC; 50-60 Hz,
 - .. From 100 to 350 V DC.
- . Maximum supply current: 1.5 A @ 85 V AC; power consumption 85 VA.
- . Test set operation: from the mains, or from an internal battery. Battery characteristics:
 - .. Type: Ni-Mh, rechargeable.
 - .. Battery operating time: 4 hours (CB tests); 1 hour (microhmmeter).
 - .. Battery charging time: 8 hours.
- . Housing: aluminium case, with hinged removable cover and handles.
- . The instrument comes complete with the following items:
 - .. Mains cable;
 - .. User's manual;
 - .. Serial cable;
 - .. USB cable;
 - .. One cable, yellow/green, for the connection to ground. Cable length: 4 m; cross section 1 sq. mm, terminated with a crocodile;
 - .. Spare fuses;
 - .. Software TDMS.
- . Dimensions: 485 (W) * 365 (D) * 240 (H) mm.
- . Weight: 15 kg.

3 OPTIONS

Options 0 to 3 and 5 are to be specified at order

3.0 CONNECTORS ON MAIN CONTACTS INPUTS.

This option has equipped with connectors instead of banana plugs on the main contacts. The cable set must of the equipment be selected accordingly to this option, that is PII42266 (two breaks per phase) , PII43266 (4 breaks per phase) , PII44266 (6 breaks per phase) or PII45266 (long cables)

3.1 STATIC AND DYNAMIC RESISTANCE MEASUREMENT.

The option performances are described at paragraphs 2.8 and 2.9. Physically, it is made of a printed circuit board, to be mounted on the mother panel, and of a capacitor, to be mounted on the base. Even if it is possible to upgrade CBA2000, it is advisable to request the option at order.

3.2 FOUR COIL COMMANDS.

With this option the test set is provided with the circuits to drive four coils (three Open, one Close), rather than two. The option is made of an additional printed circuit board that fits into the mother board.

Even if it is possible to upgrade CBA2000, it is advisable to request the option at order.

3.3 ADDITIONAL MAIN AND AUXILIARY INPUTS.

This option adds to the test set two main contact sensing circuits each phase and four auxiliary digital event inputs . In this way the instrument has the capability to verify a four chambers breaker with eight auxiliary digital event inputs.

Optionally, another board could be mounted, in order to have six main contact sensing circuits each phase (six chambers breaker test) and twelve auxiliary digital event inputs.

3.5 EXTERNAL PRINTER, CODE PII14102.

Thermal printer, for the printout of all test results. Paper 112 mm wide.

3.6 INTERNAL PRINTER.

CBA2000 can be provided with a built-in thermal printer. Printer characteristics:

- Type: thermal;
- Paper width: 58 mm;
- Recordings: the selected window.

This option is exclusive of the DC loss test.

Even if it is possible to upgrade CBA2000, it is advisable to request the option at order.

3.7 MINIMUM TRIP COIL TESTER

The option has the purpose of allowing to test the behaviour of the Minimum Trip Coil circuit and of Open or Close coils, when supplied at a reduced auxiliary voltage.

There are two modules available: one, code PII34166, is for battery voltages up to 250 V; the other one, code PII24166, is for battery voltages up to 70 V.

The option is to be connected to the auxiliary DC supply of the plant; the option output voltage can be modified (stepped or ramped down), according to the test program.

This option is exclusive of the internal printer.

Even if it is possible to upgrade CBA2000, it is advisable to request the option at order.

Options characteristics:

OPTION	PII34166	PII24166
Absolute maximum voltage	250 V	70 V
Maximum operating voltage	240 V	50 V
Minimum operating voltage	50 V	16 V
Maximum voltage drop	120 V	45 V
Minimum voltage drop	10 V	5 V
Adjustment step	2 V	0,5 V
Adjustment accuracy	2 V	0,5 V
Maximum output current	4 A; dV < 60 V; 2 A; dV > 60 V	10 A; dV < 12 V; 5 A; dV > 12 V
Maximum test duration	500 ms	500 ms
Pause duration	20 s	20 s

. Connections: one input safety socket, to be connected to the auxiliary supply positive, and one output safety socket, to be connected to the minimum voltage input.

. Voltage adjustment in steps.

. Over-current protection.

3.8 BASIC CONNECTION CABLES SET

Some connection cable sets are available; they are differentiated by number of main contacts and auxiliary cables and the connection type to the instrument (banana plugs or connectors):

	PII15169	PII55169	PII65169	PII42266	PII43266	PII44266
Breaks x phase	2	4	6	2	4	6
	Main contacts cables					
Number	3	6	9	3	6	9
Length	16m	16m	16m	18m	18m	18m
Connection to CBA2000	3 banana plugs: red, black blue	3 banana plugs: red, black blue	3 banana plugs: red, black blue	Tearproof connector	Tearproof connector	Tearproof connector
	Auxiliary contacts cables					
Number	2	4	6	2	4	6
Length	6m	6m	6m	6m	6m	6m

1. Main contacts cables (other details and photos):

- . Cross section 1 sq. mm
- . Three conductors
- . Silicone cable
- . Terminated on the CB side with three clamps: red, black and blue.

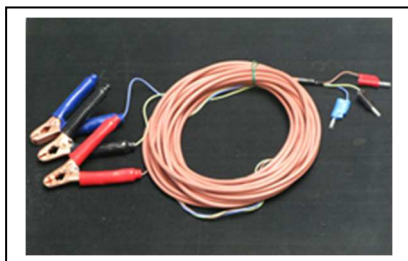

PII15169
PII55169
PII65169

Banana plugs to CBA2000

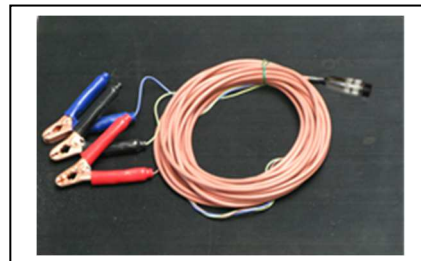

PII42266
PII43266
PII44266

Teraproof connector to CBA2000

2. Auxiliary contact cables cables (other details and photo):

- . Cross section 1 sq. mm
- . Three conductors
- . Silicone cable
- . Terminated with safety banana sockets with colors (black, red, blue) on both sides,.



PII15169 or PII42266
PII55169 or PII43266
PII65169 or PII44266

- Two cables with four conductors each, for the connection to the CB coils. Cable length: 10 m; cross section 1.5 sq. mm, terminated with safety banana sockets; colors: black, red, yellow, blue.



- One shielded cable for the measurement of the low voltage, including two conductors. Cable length: 10 m; cross section 0,5 sq. mm. Terminated with the suitable connector on the CBA2000 side, and with two clamps on the CB side.



- One set of crocodiles, 16 in all, with different colors, for the connection to auxiliary contacts and for the 500 V measurement inputs connection.



- A set of 12 cables, 2 m long, of different colors, terminated with banana plugs on both sides, for the connection to other inputs.



- A set of adaptors from banana sockets to terminators, 20 in all, with different colors, for the auxiliary contacts and for the coil inputs.



8. Eight short cables, to put in common the coils supply.



9. A cable for the MTC option.

10. Three cables for the connection to analog transducers. Length: 1 m; terminated with a 10-way connector on the CBA2000 side, and with a three-way connector on the transducer side.



11. Three adapters for the connection to analog transducers. Length: 1 m; terminated with a three-way connector on one side, and with four banana plugs on the other side.

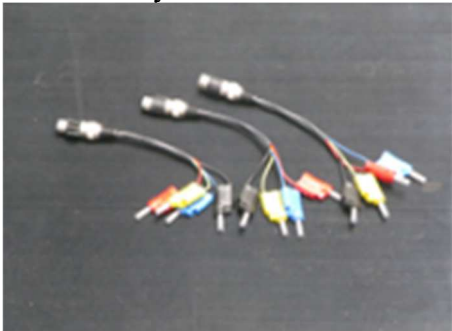

12. Three 10-way cables for the connection to digital transducers. Length 1 m; terminated with a 10-way connector on the CBA2000 side, and with seven banana sockets on the other side.



- .. One plastic bag that hosts all the cables, with wheels and handles. Dimensions: 45 x 55 x 22 cm.



If the micro-ohm meter option is included, the following connection cables are provided:

- .. Two high current cables, made of one conductor. Cable length: 10 m; cross section 25 sq. mm. Terminated with a suitable terminator on the CBA2000 side, and with an high current clamp on the CB side.



For each additional main inputs option provided, the following cables are also provided:

- .. Three cables with silicone isolator for the connection to the main contacts, each of three conductors. Cable length: 16 m; cross section 1 sq. mm. Terminated on the CBA2000 side with safety banana sockets, with colors: black, red, blue, and on the CB side with three clamps, with the same colors.
- .. Two cables with silicone isolator for the connection to the auxiliary contacts, each of three conductors. Cable length: 6 m; cross section 1 sq. mm; terminated with safety banana sockets, with colors: black, red, blue. Connection crocodiles are also provided.

3.9 LONG CONNECTION CABLES; CODE PII81169 OR PII45266

The option is the same as above, unless for the items 1 and 2. Instead of them, the option includes:

1. Six cables with silicone isolation, 38 m long, cross section 1.5 sq. mm , for the connection to main contacts, each of three conductors. Each cable is mounted on a support wheel. Terminated on the CBA2000 side with safety banana plugs, and on the CB side with three clamps, with different colors.



PII81169



PII45266

2. Six cables with silicone isolation, 2 m long, cross section 1.5 sq. mm , for the connection from CBA2000 to the above wheels.



PII81169



PII45266

3. Two cables with silicone isolator for the connection to the auxiliary contacts, each of three conductors. Cable length: 10 m; cross section 1 sq. mm; terminated with safety banana sockets, with colors: black, red, blue.



3.10 TRANSIT CASE.

The transit case allows delivering CBA2000 with no concern about shocks up to a fall of 1 m.
Protection degree: IP 65.



3.11 SOFT PROTECTION BAG.

The soft protection bag hosts CBA2000 and protects it against dust and scratches.



3.12 POSITION TRANSDUCERS.

3.12.1 Analog transducers

We have a set of analog transducers, linear and rotating. Linear transducers have different strokes, and also different IP protections: low for the TLH series, high for the LWG series. A mounting kit is also available. The table summarizes characteristics and codes.

TYPE	DESCRIPTION	STROKE (mm)	CODE
LINEAR	TLH150	150	PII11166
LINEAR	TLH225	225	PII12166
LINEAR	TLH300	300	PII13666
LINEAR	TLH500	500	PII13166
LINEAR	LWG150	150	PII26166
LINEAR	LWG 225	225	PII27166
LINEAR	LWG 500	500	PII28166
ROTATING	-	-	PII14166
-	MOUNTING KIT	-	PII16166

The mounting kit includes the following materials:

- . N. 1 Magnetic support (1);
- . N. 1 Adaptive arm (2);
- . N. 1 Small mechanical clamp (3);
- . N. 1 Big mechanical clamp (4);
- . N. 1 Support for the rotating transducer (5).
- . N. 1 Connection cable (6), 10 m long.
- . N. 1 Rotary transducer (7) (or linear transducer, or both).

The rotating transducer comes with its flexible joint. The sketch of the joint is the following one.

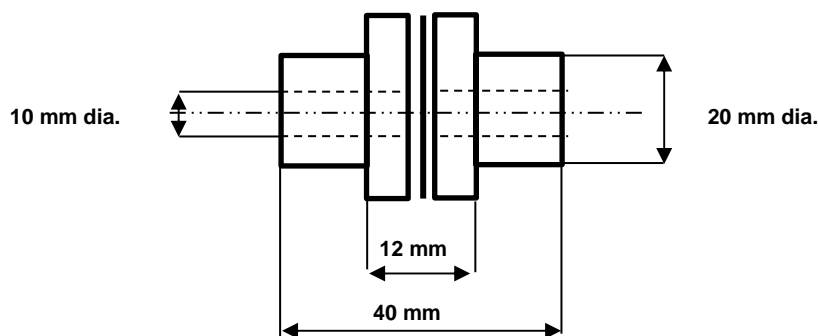

The kit is included into a plastic transport case. The following picture shows the open case.

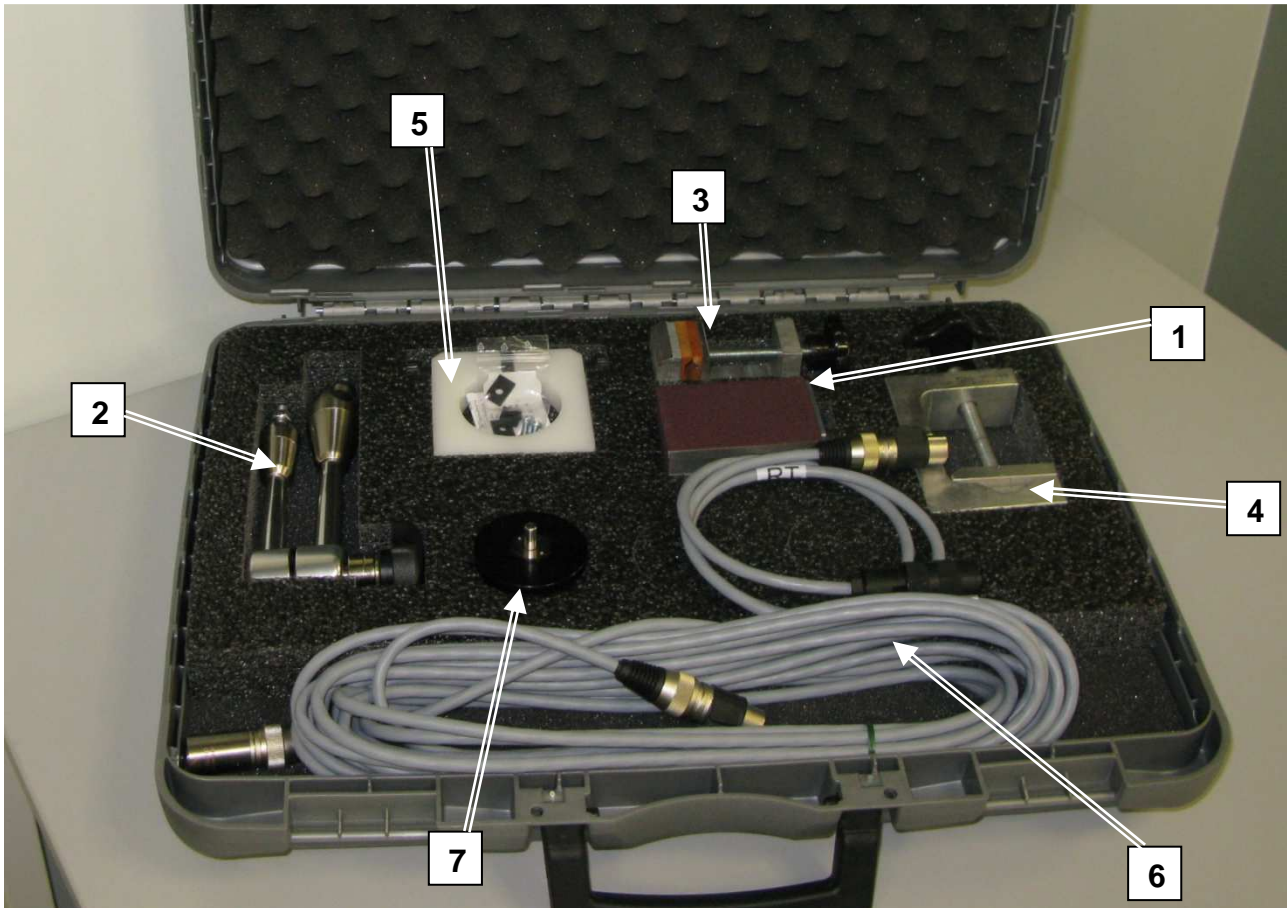

3.12.2 Digital transducers

The digital transducer option has the following characteristics.

- . Transducer name: HENGSTLER RS0-550-170;
- . Transducer type: RS422 interface; 5000 impulses per turn;
- . Connection: the transducer is connected to the test set via a shielded cable, 10 m long, terminated with a connector.

Transducer code: PII11169.

Transducer kit code: PII17169.



The mounting kit is the same as above.

3.12.3 Adaptors for mounting kit

In this kit various mechanical parts are provided in order to connect the transducers to a kinematic part of the breaker.



The description of the parts is included in the following list :

- n1 rotary transducer adapter base diameter 70mm – interaxes 50mm – screws M8
- n1 rotary transducer adapter base diameter 42mm – interaxes 20mm_X4 – screws M6
- n1 rotary transducer adapter base diameter 35mm – interaxes 20mm – screws M5
- n1 rotary transducer adapter base diameter 35mm – interaxes 20mm – screws M5
- n1 rotary transducer adapter base diameter 40mm with buttonholes
- n1 rotary transducer adapter base diameter 70mm with buttonholes
- n1 transducer extension shaft length 200mm, diameter 6mm
- n1 cylindrical screw adapter M5_Small - Hole 9mm Pin 6mm
- n1 cylindrical screw adapter M5L_M6S - Hole 10.5mm Pin 6mm
- n1 cylindrical screw adapter M6L_M8S - Hole 13.5mm Pin 6mm
- n1 cylindrical screw adapter M8L_M10S - Hole 16.5mm Pin 6mm
- n1 cylindrical screw adapter M10L_M12S - Hole 18.5mm Pin 6mm
- n1 cylindrical screw adapter M12_Large - Hole 24.5mm Pin 6mm
- n1 aluminium pin 6x20mm thread M3 for adapter base
- n1 aluminium pin 6x40mm thread M3 for adapter base
- n1 aluminium pin 6x50mm thread M3 for adapter base
- n1 aluminium pin 6x80mm thread M3 for adapter base
- n1 aluminium pin 6x100mm thread M3 for adapter base
- n1 aluminium pin 6x150mm thread M3 for adapter base
- n1 Adapter Ruland flexible joint PCMR25-6-6-A L = 31.8mm D = 25.44mm Holes 6mm
- n10 Screws M3x10 countersunk Cross head
- n2 Screws M5x45 cylindrical Cross head

n2 Screws M6x45 cylindrical Cross head
n2 Screws M8x45 cylindrical Cross head
n2 Screws M10x65 cylindrical Cross head
n2 Screws M12x65 cylindrical Cross head
n2 Screws M14x65 cylindrical Cross head

3.13 HALL EFFECT CLIP-ON TRANSFORMER FOR I MEASUREMENTS, CODE PII29166.

The Hall effect clip-on transformer allows measuring the DC current of motors and of the auxiliary supply. Main characteristics:

- . Metering: AC and DC currents.
- . DC measurement null with a knob.
- . Ranges: 10 mV/A, 80 A DC, 40 A AC maximum, and 1 V/A, 2 A DC, 1.5 A AC maximum.
- . Low battery indicator.
- . Measurement errors: 4% of reading + 20 mA for the 80 A range; 2% of reading + 5 mA for the 2 A range.
- . Phase shift (up to 65 Hz): maximum 1°.
- . Maximum working voltage: 600 V rms.
- . Power supply: alkaline 9 V battery, type 6 LR 61.
- . Service life: 70 h typical.
- . Maximum cable diameter: 10 mm.
- . Weight: 330 g.
- . Dimensions: 65 mm wide (clamp closed); 36 mm thick; 230 mm long.



3.14 AC CURRENT CLAMP, CODE PII88169.

The current clamp allows performing the first trip test: for three phase testing, three of them are necessary. The clamp ratio is 1 A//0.1 V; maximum primary current 10 A; maximum cable diameter 12 mm.



3.15 PRESSURE TRANSDUCER, CODE PII13169.

The KELLER pressure transducer type PA-21Y/40bar/81554.33 allows monitoring the variation of the SF6 pressure while the circuit breaker is operated. Main characteristics:

- . Pressure range: 0 to 40 bar (pressure differential with respect to 1 bar of the atmospheric pressure);
- . Supply voltage: 8 to 32 V DC;
- . Output voltage: 0 to 5 V DC. 0 V at the atmospheric pressure, 5 V at the absolute pressure of 41 bar;
- . Linearity error: maximum 0.5% of the range;
- . Total error, 0 to 50 °C: maximum 1% of the range;
- . Mounting: via an M12 plug, 10.5 mm long;
- . Connection to CBA2000: via a 10 m long cable, provided, terminated with the four-poles female connector on the transducer side, and with the 10 poles male connector on the CBA side;
- . Once connected, CBA2000 provides the power supply, and the transducer is ready for the measurement.

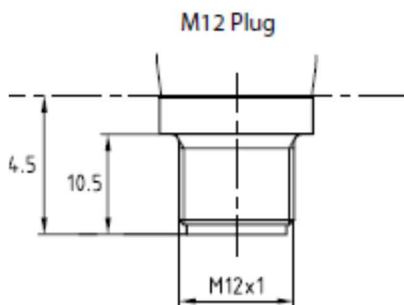

4 PROTECTIONS

- Fuse on the mains supply.
- At power-on, a diagnostic sequence controls the microprocessors. If something is wrong, the operator is alerted by a message.
- The test is started pressing the START pushbutton, and then also pushing the multifunction knob.
- During the test, the circuits driving the coils give alarm messages in case of: selected current range exceeded (short circuit included); coil driver over-temperature.
- During the test, if the trigger criteria (coil current, auxiliary input, analog input) is not met within the maximum test time, the test set displays a warning message.
- The 5 V transducer supply is protected against short circuit on the output, and against contact with a voltage up to ± 500 V. In both instances, the circuit is not damaged.
- All inputs and outputs are isolated between them.

APPENDIX A: MENU SELECTIONS

LEVEL 1	LEVEL 2	LEVEL 3	LEVEL 4	
1 TRIGGER OPTIONS	1 Coil current	% of range (1 to 99)		
	2 Coil command			
	3 Coil command reset			
	4 Analog input	1 Threshold, positive or negative 2 input range		
	5 External trigger on Slave input			
	6 Auxiliary input	1 Channel number		
		2 Logic level: NO, NC, TRANSITION		
		3 Logic conditions: AND, OR		
2 TEST OPTIONS	1 Open	A, B, C, AB, BC, CA, all; *		
	2 Close			
	3 Open – Close			
	4 Close – Open			
	5 Open – Close – Open			
	6 Optional MTC		1 Battery voltage	
			2 V threshold, %	
			3 V threshold, V	
	7 Tolerances		Max trip time	
			Max close time	
			Pole discrepancy open	
			Pole discrepancy close	
			Contact discrepancy open	
		Contact discrepancy close		
3 RECORDING OPTIONS	1 Open coil duration			
	2 Close coil duration			
	3 Open to close delay			
	4 Close to open delay			
	5 Pretrigger duration			
	6 Sample frequency			
	7 Recording duration			
	8 Two recordings		1 First duration	
			2 Dead time	
		3 Second duration		
9 Help diagram		Timing diagram		
LEVEL 1	LEVEL 2	LEVEL 3	LEVEL 4	

4 BREAKER AND AUXILIARY CHANNEL SETTINGS	1 Breaker contacts	A1; A1+B1+C1; all **			
	2 Pre-insertion resistor test	Enable/disable			
	3 Auxiliary inputs 1-2 **	Enable/disable; Label; Dry/wet			
	4 Auxiliary inputs 3-4 **	Enable/disable; Label; Dry/wet			
5 ANALOG CHANNEL/COILS SETTINGS	1 Close coil range	2.5,10,25 A			
	2 Open coils range	2.5,10, 25 A			
	3 Analog input	1 Enabled			
		2 500 V input range, label		500,50,5 V DC	
		3 Travel transducer	Label		
			Phase		
			Transducer: U.M.;		
			Transducer: max stroke		
			Supply: 5V int, ext		
			Breaker: U.M.;		
			Breaker: stroke; Nominal transducer stroke		
		Travel transducer calibration	Open position, %		
			Closed position, %		
			Actual tr. stroke, %		
Tr. stroke error, %					
Actual bk. stroke, %					
Datum points definition	Enable				
	From open to closed	At open position			
At closed position					
At CB opening					
A point set-up					
	B point set-up				

LEVEL 1	LEVEL 2	LEVEL 3	LEVEL 4
		From closed to open	At open position At closed position At CB opening A point set-up B point set-up
		4 Pressure transducer	Input: 5 V, 500 V 1 U.M. (Bar, ..) 2 Pressure at zero voltage 3 Volt per pressure
		5 Clip-on transformer	Input: 5 V, 500 V 1 Label 2 I/V ratio 3 Max I
6 MICROOHMMETER	1 Disabled		
	2 Static contact resistance	1 Nominal test current	20, 100, 200 A
		2 Resistance range	200 μ Ohm; 1; 10; 100 mOhm
		3 Test mode	1 Single 2 Breaker phase
	3 Dynamic contact resistance	1 Nominal test current	20,100, 200 A
		2 Resistance range	200 μ Ohm; 1; 10; 100 mOhm
7 RESULTS	1 Save result	Result name	
	2 Load result	List of results	
	3 Delete result	List of results	
	4 View result	List of results	
	5 Delete result	List of results	

* Only with the four coils option

** More selections if mounted main and auxiliary inputs option(s)

LEVEL 1	LEVEL 2	LEVEL 3	LEVEL 4
8 PREFERENCES	1 Date and time		
	2 Display	1 Contrast	
		2 Backlight duration	
	3 Time measurement	ms; 60 Hz cycles; 50 Hz cycles	
	4 Debounce	ms	
	5 Buzzer	Yes - No	
	6 Print diagrams	Yes - No	
9 SETUP options	1 Save setup	Name	
	2 Load setup	List of files	
	3 Delete setup	List of files	
	4 Show setup	Name; trigger...	
	5 Show current setup	Name; trigger...	
	6 Restore default		
10 Tests header	Plant, feeder..		
11 Test diagram	Measurements		
	Results table		
	Zoom in-out		
	Function keys		